

Objective	1
Planning the Loading Station	
■ Transport vehicles	2
■ Utilization of the building	3
■ Existing site conditions	3
Constructional Aspects	
■ Clearances	4
■ Preparing a loading trough	5
■ The correct platform height	6
■ Saw-tooth configuration	7
■ Canopy	8
■ Tailboard slot	8
■ Power supply connection	8
Vehicles / Handling Equipment	
■ Lorries	9
■ Floor conveyors	10
Product Overview / Equipping the Loading Station	
■ Dock levellers	11
■ Dock shelters/seals	11
■ Dock buffers	12
■ Vehicle alignment guides and roadway marking	12
■ Immobilizers for lorries	13
■ Signalling systems	13
■ Lighting	13
■ Pedestals	14
■ Loading houses	14

Basic principles



Objective

Why invest in loading equipment? –
In order to reduce loading costs!

Hörmann loading technology offers fully developed system solutions for the following frequently occurring problems:

■ Loading and unloading is extremely time-consuming. Cause: The difference in height between the vehicle decks and the warehouse floor. **Hörmann dock levellers not only bridge the gap but also the difference in height, thereby allowing efficient loading and unloading in a single horizontal movement** (into the lorry/out of the lorry).

■ While loading and unloading the risk of catching a chill or coming down with some other ailment increases considerably. Being exposed to the elements is detrimental to both personnel and goods.

Hörmann's extensive range of dock shelters and seals offers tailored solutions to cater for a wide variety of vehicles and goods.

■ A vehicle that does not dock accurately can cause structural damage to the building.

Hörmann offers wheel guides as well as a wide range of different dock buffers to absorb the impact of docking vehicles and thereby protect the front of the building.

■ Accidents can be caused when vehicles are driven away from the dock prematurely.

Hörmann wheel lock systems ensure that the vehicle always stays safely and securely docked.

■ To optimize the loading and unloading process, Hörmann offers a comprehensive range of loading equipment right through to complete, ready-to-install loading houses. Dock lights, wheel guides, signalling systems etc. transform your loading platform into a safe and efficient loading station.

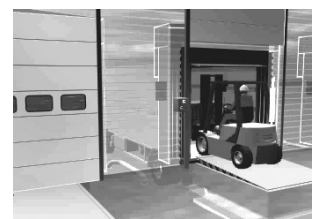
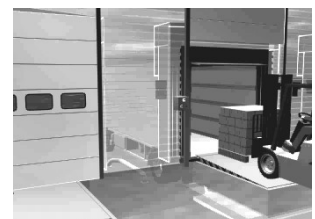
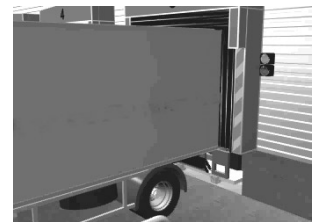
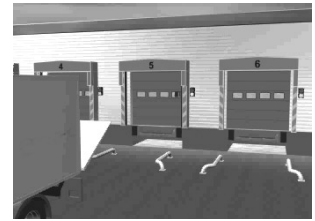

Planning the Loading Station

In order to gain maximum benefit from the loading equipment on the loading platform, it is extremely important to inform oneself comprehensively beforehand.

The most important aspect when planning a loading station is to take stock of the situation to establish where the priorities lie. The key influential factors are:

- Type and number of transport vehicles
- Driving habits of the drivers
- Type of use the building is put to
- as well as existing, potentially restrictive structural conditions

■ Transport vehicles

Type

What type of vehicles dock at the loading platform?

The dimensions, variability as well as type of goods being loaded play a key role in determining the choice of equipment.

Number of vehicles

How many vehicles arrive at the same time?

Research how many loading stations will be needed in relation to the number of vehicles that will be arriving at the same time, while also bearing in mind the loading times of the vehicles. You can then work out the manoeuvring space that will be needed.

Drivers

Take the driving habits of the lorry drivers into consideration!

It's easier for the lorry driver to reverse in a CLOCKWISE rather than an ANTI-CLOCKWISE direction (provided the vehicle is a left-hand drive) and this also gives the driver a clearer view.

The space a good driver needs in order to drive and park a lorry combination in front of the building without difficulty, should never be undercalculated. Corresponding recommendations can be obtained from the Professional Association of Hauliers.

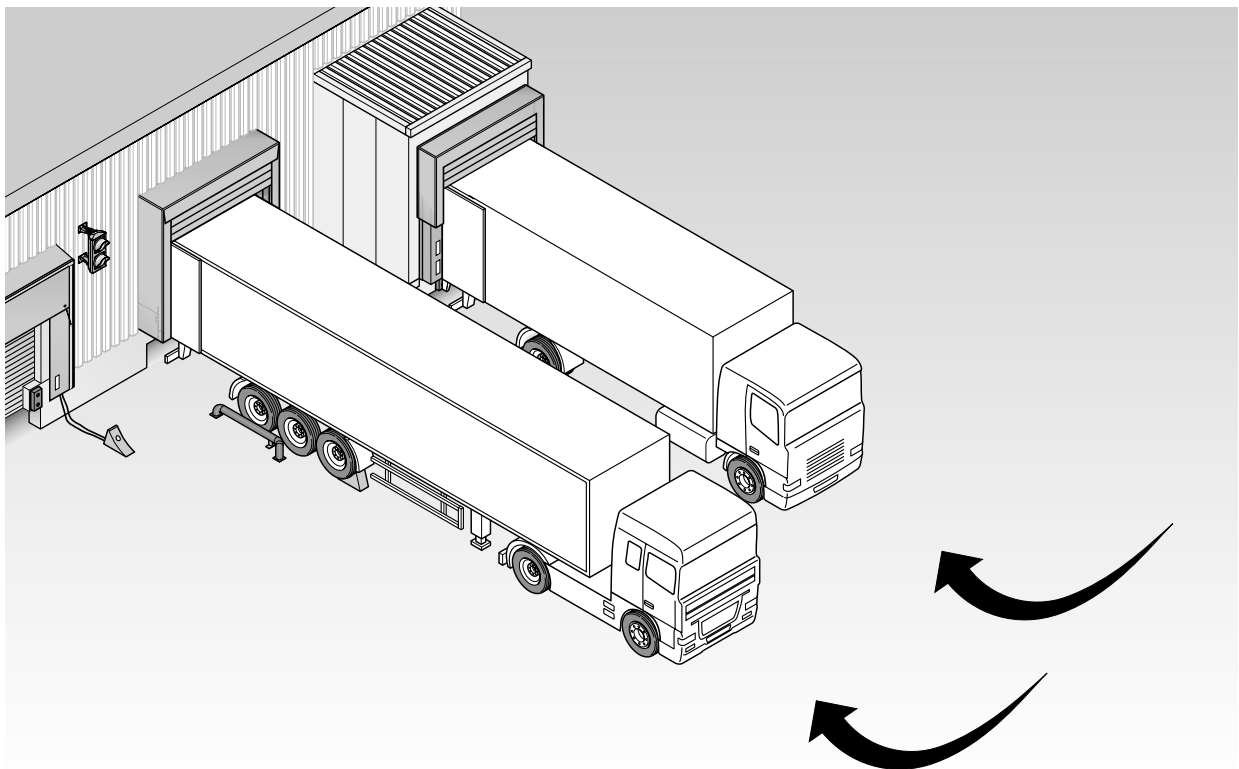

Planning the Loading Station

■ Utilization of the building

Take the differing requirements into consideration, for e.g. a warehouse, production facility or cold store.

How will the goods be conveyed to the loading terminal?

What handling equipment will be used for loading?

Make sure that you use short efficient routes and that the loading terminal is suitably equipped for the handling equipment deployed.

Are the Incoming Goods and Outgoing Goods areas to be kept separate? It may be advisable to locate loading stations on more than one side of the building.

Will loading also take place at night? Make sure that the loading station is adequately lit.

■ Existing site conditions

If a loading platform is already available, check whether the height meets the requirements and select the equipment of the loading station accordingly.

Is the warehouse floor elevated or is the loading zone set lower?

Is adequate manoeuvring space available to allow a vehicle to dock straight or is docking at an angle necessary?

What products can simplify the logistics process?

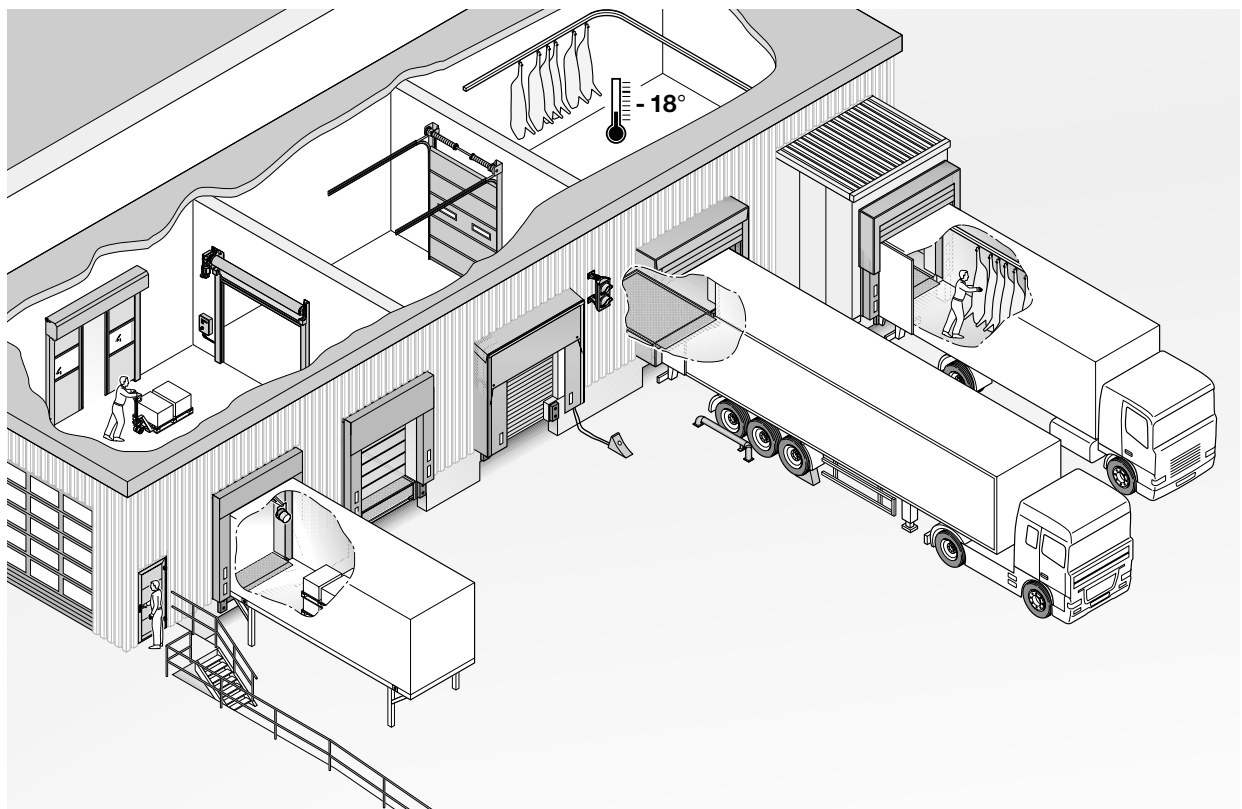

■ Clearances

Between two loading stations a distance of 4000 mm from door centre to door centre is necessary to ensure that also wider lorries will be able to open their doors.

From the centre of the outer door to the turning wall a clearance of 2750 mm is required.

The size of the dock door should be approx. 3000 x 3000 mm (WxH). Pay attention here to the dimensions of the door shelter/seal.

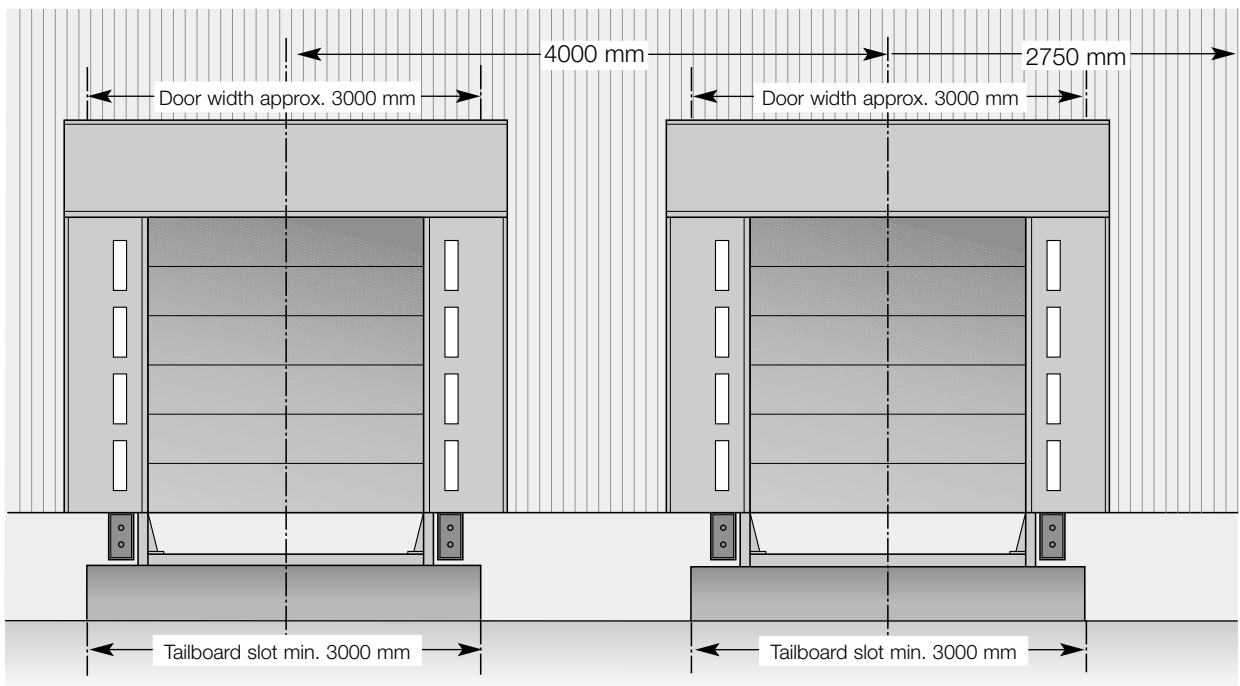

■ Preparing a loading trough

The difference in height between the loading platform and the vehicle deck should be as small as possible!

If the warehouse floor is lower than the vehicle deck, then a deeper loading trough is necessary. If this is possible, the other alternative would be to raise the warehouse floor.

The loading trough must offer sufficient space to allow trouble-free, straight-line docking. An expensive loading trough which does not prove its worth in practice is a poor investment.

Drainage

To provide drainage on the level section, we recommend a gradient of 1% in the direction of the kink. This prevents any water that has collected on the roof of the lorry from running off towards the dock shelter/seal.

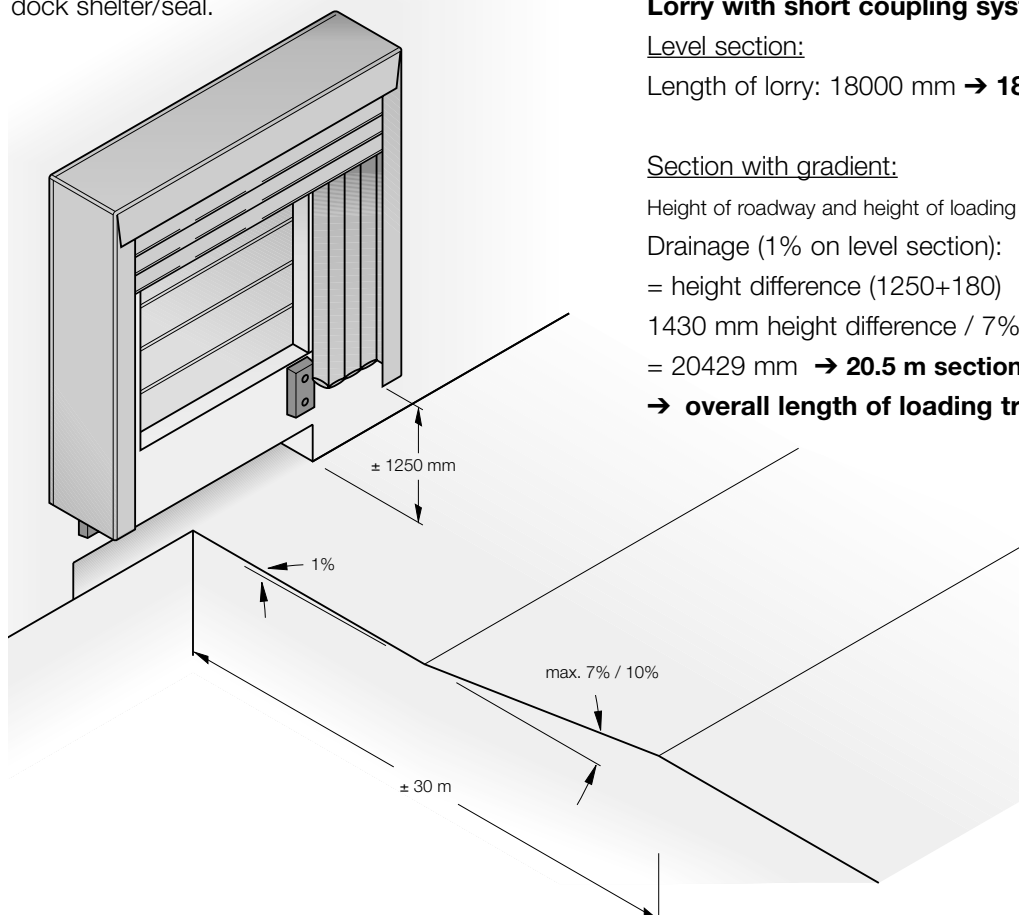

The correct size

The optimum length of the loading trough - not including manoeuvring space - should result from

- a level section of approx. 18 m corresponding to the length of the lorry
- plus a specific section with gradient

Note: in the meantime there are even some articulated lorries with trailers that are up to 25.25 m long.

The length of the section with gradient depends on two factors:

- Vehicle: most vehicles permit a gradient of up to 10%. In the case of short coupling systems the gradient is limited to 7%.
- Difference between the height of the roadway and the height of the loading platform.

Calculation example:

Lorry with short coupling system

Level section:

Length of lorry: 18000 mm → **18 m level section**

Section with gradient:

Height of roadway and height of loading platform: 1250 mm
Drainage (1% on level section): 180 mm
= height difference (1250+180) 1430 mm
1430 mm height difference / 7% max. gradient
= 20429 mm → **20.5 m section with 7% gradient**
→ **overall length of loading trough: 37.286 m**

■ The correct platform height

To summarize: the difference in height between the loading platform and the vehicle deck should be kept as small as possible!

Ideally, the loading platform should be slightly higher than the vehicle deck of the most frequently docking lorries.

This produces a favourable angle of inclination and at the same time prevents the lorries from driving beyond the buffers.

In the case of mixed transport, in other words various loading floor heights, choose an average platform height, corresponding to the majority of the vehicles docking.

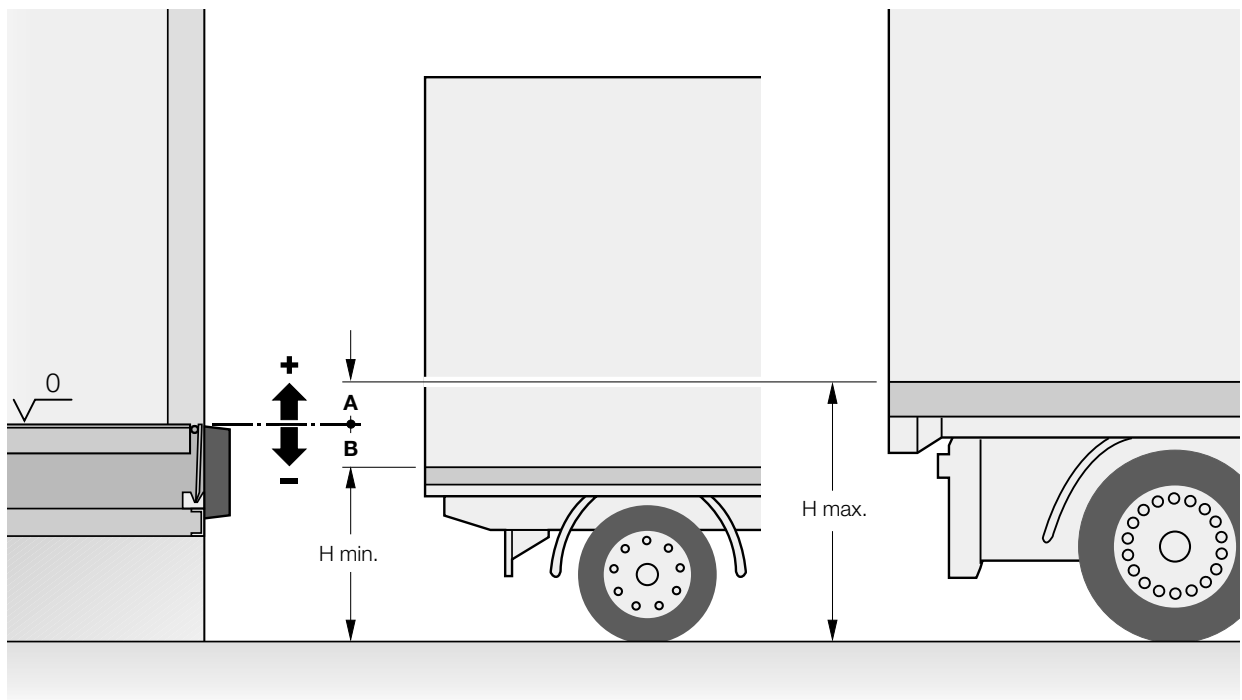

If it is not possible to excavate the loading trough in front of the building, then the working height of the building can be matched to the average height of the vehicle deck by using pedestals.

However, there still continues to be a difference in height between the vehicle decks of the various lorry types (between 650 mm and 1650 mm)! If these differences prove to be too great, then a stepped loading trough often provides a better solution.

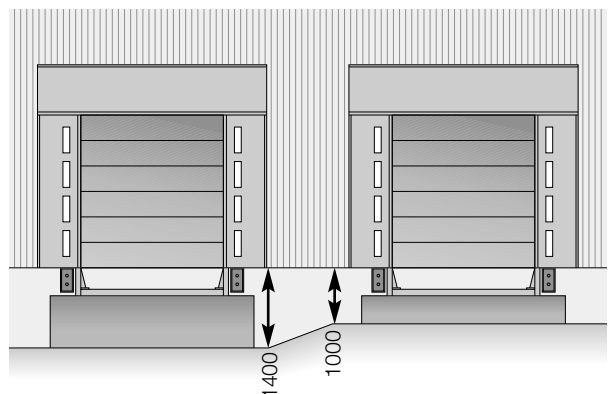

■ Saw-tooth configuration

If the distance to the road is too short and an internal loading platform is unfavourable or not possible, then a saw-tooth configuration can offer the best solution to allow the manoeuvring space to be increased to an acceptable size.

This can be achieved quickly and easily - also at a subsequent date - simply by using pedestals with a loading house on top. The entire construction is then set at an angle to the building.

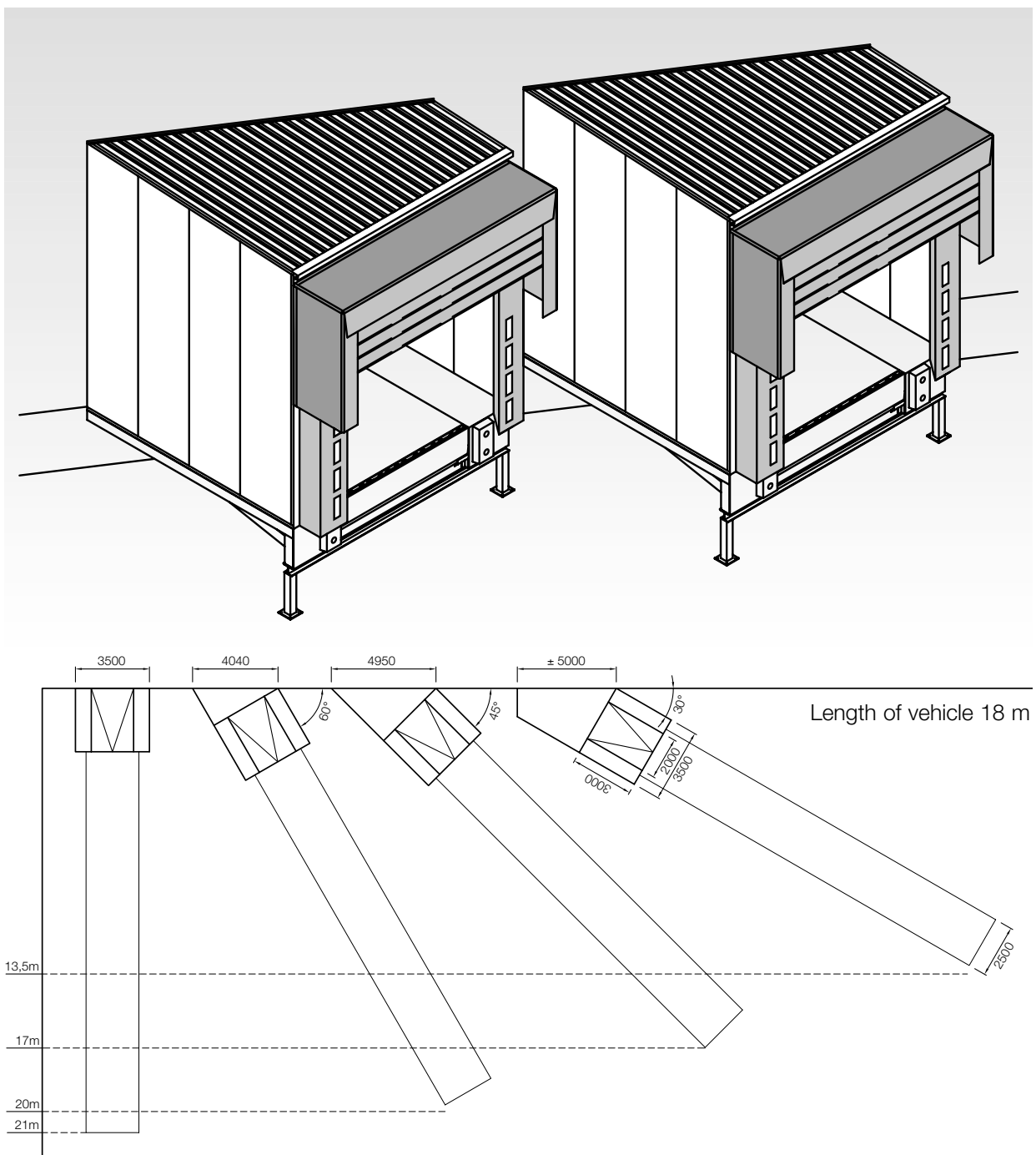

■ Canopy

If the building is equipped with a canopy, this must be installed at an adequate height, for lorries up to a max. height of 4000 mm, at least 4750 mm above the roadway level!

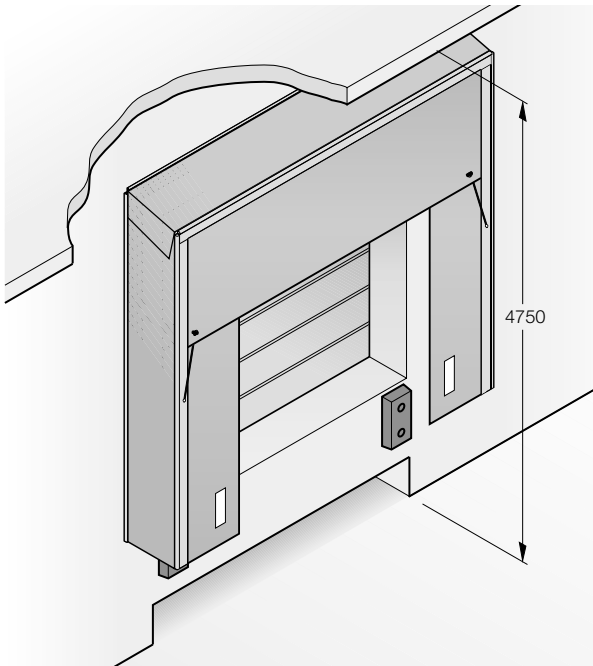

The background:

Air-sprung transporters are able to bring their low loading deck closer to the height of the ramp.

The dock leveller's angle of inclination/tilt is reduced and working at the loading platform becomes considerably more comfortable.

The overall height of the lorry is then possibly 500 mm greater than the usual height of 4000 mm and that permitted for driven vehicles.

In a number of countries there are lorries on the road that are even higher than this. This is why the canopy should not be set too low.

Also with the so called "short coupling system" the back end is pressed upwards on account of the special construction.

■ Tailboard slot

A deep, wide recess must be provided underneath the dock leveller to accommodate the hydraulic tailboards of the lorries. Lorries whose tailboard does not fit underneath the dock leveller or the loading platform, therefore stand a tailboard distance away from the front of the building. As a result, the dock shelter/seal proves useless or a special dock shelter/seal must be made.

A tailboard slot is a constructional feature.

With the Hörmann box model dock leveller, this can be achieved quickly and at minimum cost. After pouring in the concrete and allowing it to cure, the timber underframe is removed and the tailboard slot is ready for use (see Section "Dock Levellers/Installation Models").

If the building does not allow a tailboard slot, then another good option is to use a loading house (see Section "Loading Houses").

■ Power supply connection

For connecting the electric hydraulics of a dock leveller, a PVC tube of 50 mm Ø must be set into the concrete and a 400 V connection installed (see "Detailed Drawings for Dock Levellers").

■ Lorries

Depending on the type of lorry, varying dimensions and equipment must be taken into account:

Width

As a rule, the width of lorries lies in the range **2500 to 2600 mm**, in compliance with the European Standard.

Delivery vans are approx. 2000 to 2300 mm wide.

Height

The average lorry height varies between **approx. 3300 and 4000 mm**.

In some countries, such as England or Finland, even heights of up to 4500 or 5000 mm can be found.

When the suspension of vehicles is fully raised, the maximum permissible height can at times be exceeded!

Delivery vans are approx. 2800 to 3100 mm high.

Lorry sizes and designs are individually matched to the goods to be transported, ranging from large-capacity lorries with a low weight to small-capacity lorries with a higher weight, e.g.

- large-volume transport
- jumbo vehicles
- with short coupling system
- with through-loading facilities

The height should be used to the optimum:

- A low-lying vehicle deck on account of smaller wheels, provides greater volume.
- An intermediate floor increases the loading capacity.
- Shorter traction engines make it possible to use longer trailers.

Vehicle deck height

The most frequently occurring deck heights:

- 650/800 to 1000 mm (large-volume transport)
- 650/800 to 1100 mm (delivery van)
- 1100 to 1300 mm (normal transport)
- 1300 to 1500 mm (refrigerated transport)
- 1400 to 1600 mm (container transport)

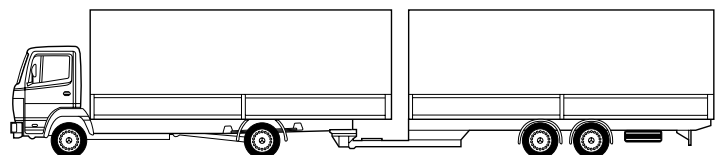
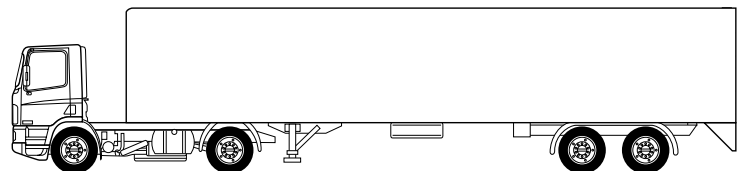
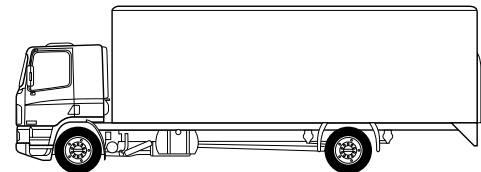
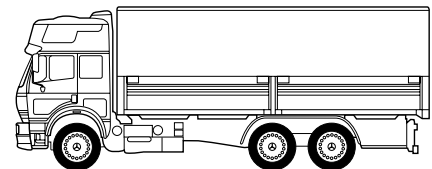
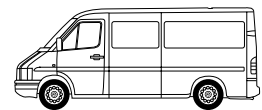

Equipment

The equipment options are, for e.g.:

- (hydraulic) tailboard
- air suspension
- double doors or flap
- interchangeable leveller
- refrigerated transporter
- overhead conveyor (meat)

■ Floor conveyors

Are different types of floor conveyors used?

How high is the overall weight, made up of the lorry's empty weight, the weight of the auxiliary equipment and the load to be transported?

What is the maximum incline that the used floor conveyors permit?

What types of wheels are used on the forklift trucks?

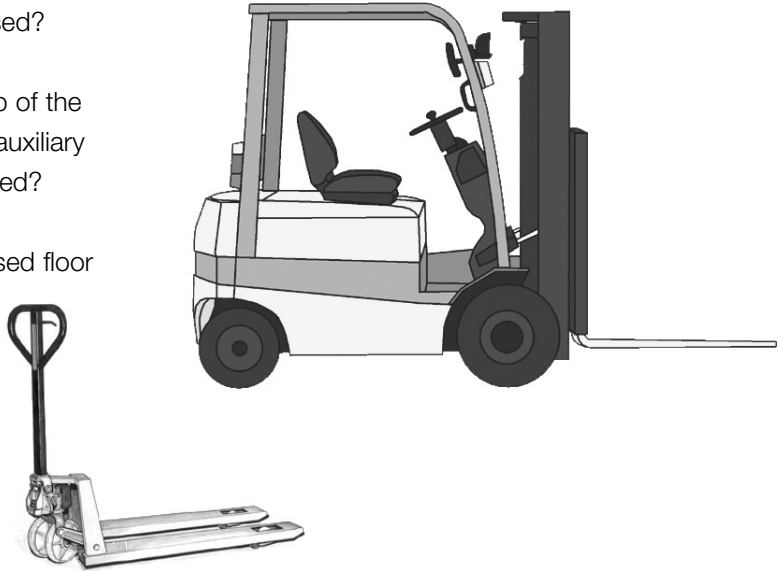

Efficient transportation means:

- maximum payload per journey
- quickest possible loading and unloading

■ Dock levellers

They bridge the gap between the lorry and the loading platform and level the difference in height via an electric hydraulic system with 2 main cylinders. In accordance with DIN EN 1398, in order to remain within the safety guidelines, an incline of up to 12.5% is permissible.

HLS-2

with hinged lip, 405 mm long,
with open lip hinge

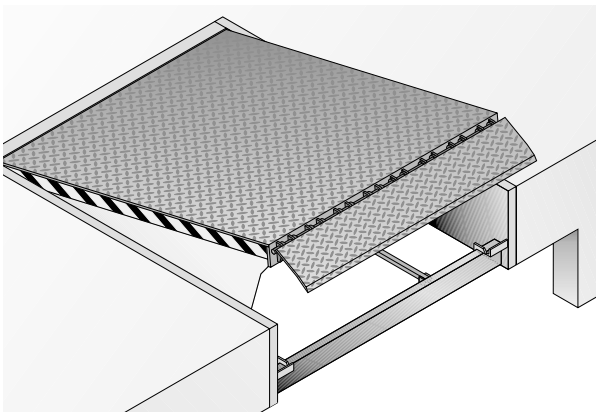

HTL-2

with telescopic lip, 500 or 1000 mm long,
for precise positioning

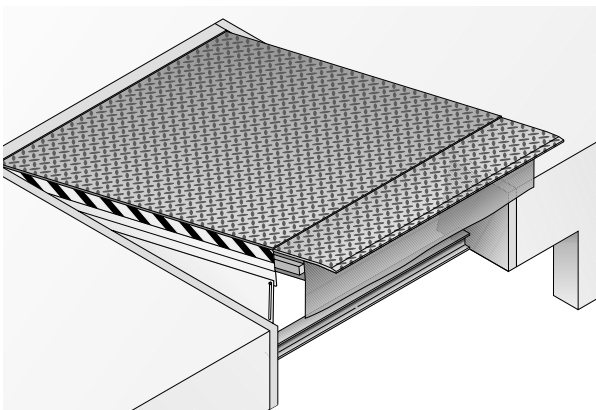

■ Dock shelters/seals

They seal the intermediate space between the door opening and the lorry.

Flap shelters

DSL/DSS

Compressible link and scissor arm construction, resilient side flap material thanks to a monofilament insert, available as a dock-height, roadway or a recess-installed version.

DTL/DTS

Retractable link or scissor arm construction, particularly low wear thanks to the steel leaf springs integrated into the flaps, available as a dock-height, roadway or recess-installed version.

DDF

with rising roof and foam-filled side cushions, also suitable for vehicles with rising suspension. Dock-height model.

Inflatable and combined dock shelters/seals

DAS-3

Produces a particularly good seal for all lorry sizes, available as a dock-height, roadway or recess-installed version.

DAK-3

Inflatable top cushion as on DAS-3, combined with fixed side cushions.

Cushion seals

DFH

with fixed top and side cushions.

DFC

with top flap in place of a top cushion.

DAH

with adjustable top cushion.

■ Dock buffers

NO LOADING PLATFORM SHOULD BE WITHOUT THEM!

They absorb the forces that are generated each time a vehicle docks, thereby ensuring that the dock shelter/seal and platform do not get damaged in the process. These forces can well be as high as 650 kN, e.g. when a 30 t lorry docks at a speed of 6 km/h.

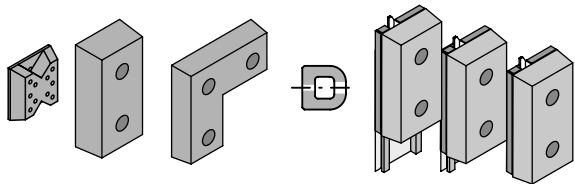

Depending on what is needed, various mounting plates, mounting brackets as well as fixings are available. Where greater wear and tear is expected, we recommend using protective plates on the front of the dock buffers.

■ Vehicle alignment guides and roadway markings

Vehicle alignment guides are devices which guide lorries towards the dock opening.

Front of vehicle alignment guides: 4500 mm in front of the dock shelter/seal, internal spacing 2600 mm.

Yellow or white marker stripes on the roadway are an additional possibility, internal spacing 2500 mm.

In situations without a loading platform, door protection bollards protect the dock shelter/seal from sustaining collision damage.

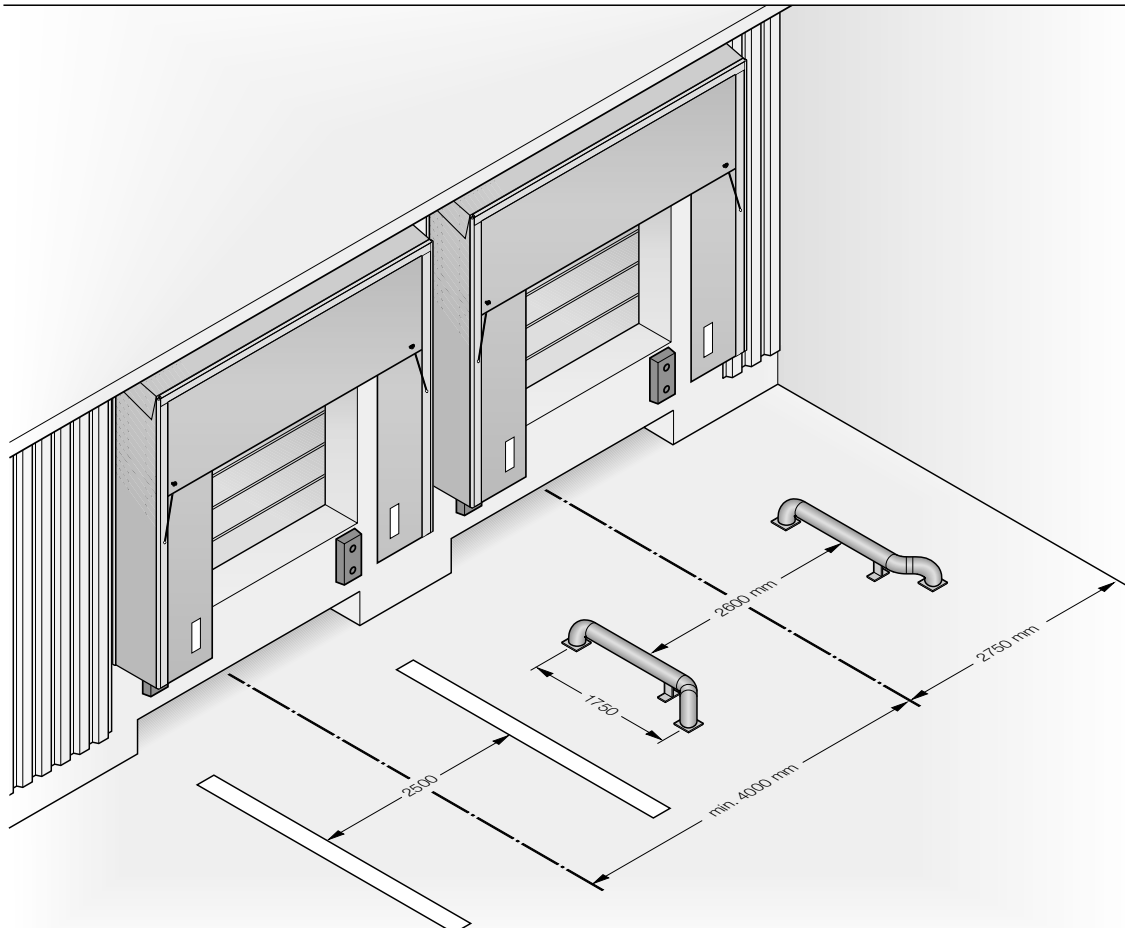

■ Immobilizers for lorries

During loading and unloading at the dock the lorry's position can shift due to the braking of the forklift truck when it drives onto the vehicle deck. Wheel chocks make sure that this cannot happen. In this way accidents can be prevented.



A wheel chock with sensor together with a signalling system provides an additional means of control and safety.

■ Signalling systems

Signal lights in various versions, combined with photocells, proximity switches and/or immobilizers ensure adequate safety at the loading station.



■ Lighting

For the safety and security of both the personnel and goods, it is essential that the workplace is adequately lit. In the case of dock shelters/seals a dock light is sufficient. For a loading house we recommend using a translucent roof or a dock light.



Located in an impact-resistant housing, it swivels round and fully illuminates the lorry during the loading and unloading process.

■ Pedestals

Pedestals are steel substructures with tailboard access. A dock leveller as a pit model can be quickly and easily inserted and welded in place.

Pedestals can also be positioned at an angle, e.g. to achieve a so called saw-tooth configuration.

■ Loading houses

If for whatever reason, loading platforms are not possible within the building or there is no tailboard access, then loading houses can be placed in front of the building.

The fully equipped loading house comprises:

- **pedestal with dock leveller**
- **wall and ceiling cladding**
- **opening for loading with dock shelter/seal**
- **dock buffers**

