

INDEX

CE DECLARATION OF CONFORMITY FOR MACHINES	2
WARNINGS FOR THE INSTALLER	2
1. DESCRIPTION AND TECHNICAL SPECIFICATIONS	3
2 ELECTRIC PREPARATIONS (standard system)	4
3 BARRIER DIMENSIONS	4
4 INSTALLING THE AUTOMATED SYSTEM	4
4.1 PRELIMINARY CHECKS	4
4.2 MASONRY FOR FOUNDATION PLATE	4
4.3 MECHANICAL INSTALLATION	4
5 START-UP	6
5.1 ADJUSTING THE BALANCING SPRING	6
5.2 CONNECTION TO CONTROL BOARD	6
5.3 ADJUSTING THE TRANSMITTED TORQUE	6
5.4 ADJUSTING THE TRAVEL LIMIT SLOW DOWN	6
5.5 AUTOMATED SYSTEM TEST	7
6 MANUAL MODE OPERATION	7
7 RESTORING NORMAL OPERATION MODE	7
8 MAINTENANCE	7
8.1 PRELIMINARY CHECKS	7
8.2 CHECKING OF SAFETY DEVICES	7
8.3 TOPPING UP OIL	7
8.4 BLEEDING OPERATION	7
9 REPAIRS	7
10 CHANGING THE RH (LH) VERSION OF THE BARRIER INTO THE LH (RH) VERSION	8
11 AVAILABLE ACCESSORIES	9
11.1 ANTI-VANDAL VALVE	9
11.2 AUTOMATIC EMERGENCY RELEASE	9
11.3 FORK SUPPORT	9



Read this instruction manual to the letter before you begin to install the product.



Symbol highlights notes that are important for people's safety and for the good condition of the automated system.
Symbol draws your attention to the notes about the product's characteristics or operation.

CE DECLARATION OF CONFORMITY FOR MACHINES (DIRECTIVE 98/37/EC)

Manufacturer: FAAC S.p.A.

Address: Via Benini, 1 - 40069 Zola Predosa BOLOGNA - ITALY

Declares that: Barrier mod. 620 SR

- is built to be integrated into a machine or to be assembled with other machinery to create a machine under the provisions of Directive 98/37/EEC and subsequent amendments 91/368 EEC, 93/44 EEC and 93/68 EEC;
- conforms to the essential safety requirements of the other following EEC directives:

2006/95/EC Low Voltage Directive
2004/108/EC Electromagnetic Compatibility Directive

Furthermore, the manufacturer declares that the machinery must not be put into service until the machine into which it will be integrated or of which it will become a component has been identified and its conformity to the conditions of Directive 89/392/EEC and subsequent modifications assimilated in Italian National legislation under Presidential Decree No. 459 of 24 July 1996 has been declared.

Bologna, 01 March 2008

The Managing Director

A. Bassi

WARNINGS FOR THE INSTALLER

GENERAL SAFETY OBLIGATIONS

- 1) **ATTENTION! To ensure the safety of people, it is important that you read all the following instructions. Incorrect installation or incorrect use of the product could cause serious harm to people.**
- 2) Carefully read the instructions before beginning to install the product.
- 3) Do not leave packing materials (plastic, polystyrene, etc.) within reach of children as such materials are potential sources of danger.
- 4) Store these instructions for future reference.
- 5) This product was designed and built strictly for the use indicated in this documentation. Any other use, not expressly indicated here, could compromise the good condition/operation of the product and/or be a source of danger.
- 6) FAAC declines all liability caused by improper use or use other than that for which the automated system was intended.
- 7) Do not install the equipment in an explosive atmosphere: the presence of inflammable gas or fumes is a serious danger to safety.
- 8) The mechanical parts must conform to the provisions of Standards EN 12604 and EN 12605.
For non-EU countries, to obtain an adequate level of safety, the Standards mentioned above must be observed, in addition to national legal regulations.
- 9) FAAC is not responsible for failure to observe Good Technique in the construction of the closing elements to be motorised, or for any deformation that may occur during use.
- 10) The installation must conform to Standards EN 12453 and EN 12445.
For non-EU countries, to obtain an adequate level of safety, the Standards mentioned above must be observed, in addition to national legal regulations.
- 11) Before attempting any job on the system, cut out electrical power.
- 12) The mains power supply of the automated system must be fitted with an all-pole switch with contact opening distance of 3mm or greater. Use of a 6A thermal breaker with all-pole circuit break is recommended.
- 13) Make sure that a differential switch with threshold of 0.03 A is fitted upstream of the system.
- 14) Make sure that the earthing system is perfectly constructed, and connect metal parts of the means of the closure to it.
- 15) The automated system is supplied with an intrinsic anti-crushing safety device consisting of a torque control. Nevertheless, its tripping threshold must be checked as specified in the Standards indicated at point 10.
- 16) The safety devices (EN 12978 standard) protect any danger areas against **mechanical movement Risks**, such as crushing, dragging, and shearing.
- 17) Use of at least one indicator-light (e.g. FAACLIGHT) is recommended for every system, as well as a warning sign adequately secured to the frame structure, in addition to the devices mentioned at point "16".
- 18) FAAC declines all liability as concerns safety and efficient operation of the automated system, if system components not produced by FAAC are used.
- 19) For maintenance, strictly use original parts by FAAC.
- 20) Do not in any way modify the components of the automated system.
- 21) The installer shall supply all information concerning manual operation of the system in case of an emergency, and shall hand over to the user the warnings handbook supplied with the product.
- 22) Do not allow children or adults to stay near the product while it is operating.
- 23) Keep radiocontrols or other pulse generators away from children, to prevent the automated system from being activated involuntarily.
- 24) Transit is permitted only when the automated system is idle.
- 25) The user must not attempt any kind of repair or direct action whatever and contact qualified personnel only.
- 26) Maintenance: check at least every 6 months the efficiency of the system, particularly the efficiency of the safety devices (including, where foreseen, the operator thrust force) and of the release devices.
- 27) **Anything not expressly specified in these instructions is not permitted.**

AUTOMATED SYSTEM 620 SR

The automated system is composed of a steel upright, within which is the operator composed of a hydraulic control unit and two plunging pistons which, by means of a rocker, rotate the beam. The beam stays balanced thanks to a balancing spring assembled on one of the plunging pistons. The electronic control unit is also housed in the upright, inside a waterproof compartment. The system is supplied with an adjustable anti-crushing safety device; it also includes a device ensuring stopping and locking of the beam in any position and a handy manual release for use in case of power cuts or faults.

 **The 620 SR automated systems were designed and built to control vehicle access. Do not use for any other purpose.**

ENGLISH

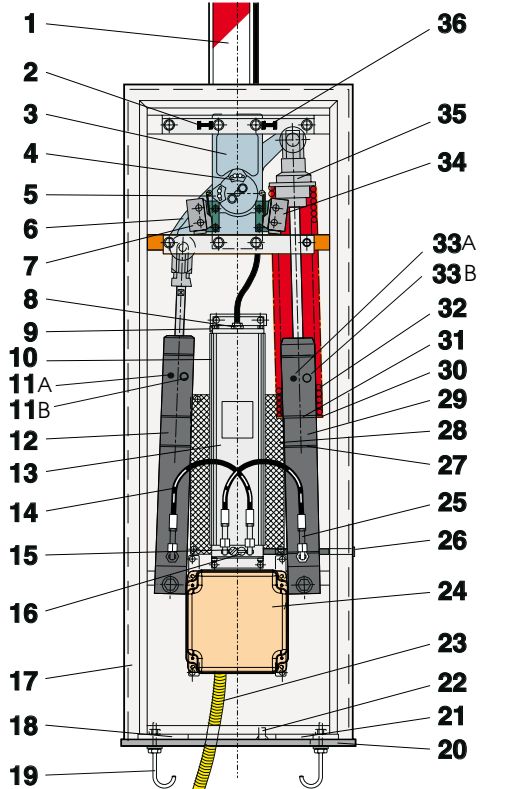

- | | |
|---------------------------------------|---|
| 1 Beam | 18 Hole for cables LH |
| 2 Travel limit mechanical stop device | 19 Tie rod |
| 3 Drive transmission unit | 20 Foundation plate |
| 4 Adjustable travel limit cam RH | 21 Hole for cables RH |
| 5 Adjustable travel limit cam LH | 22 Earth connector securing screw |
| 6 Rocker | 23 Cable routing sheath |
| 7 LH travel limit device | 24 Electronic control board |
| 8 Oil filling plug | 25 Feeder pipe RH |
| 9 Breather screw | 26 Manual release |
| 10 Cooling fins | 27 Spring support position, length 460 mm |
| 11A Piston bleed screw LH | 28 Protective grid for air intakes |
| 11B LH deceleration adjustment screw | 29 Plunging piston RH |
| 12 Plunging piston LH | 30 Spring support position, length 400 mm |
| 13 Hydraulic control unit | 31 Balancing spring support |
| 14 Feeder pipe LH | 32 Balancing spring |
| 15 CLOSING by-pass screw | 33A Piston bleed screw RH |
| 16 OPENING by-pass screw | 33B RH deceleration adjustment screw |
| 17 Upright | 34 Travel limit device RH |
| | 35 Balancing adjustment ring-nut |
| | 36 Travel limit mechanical stop device |

Fig. 1

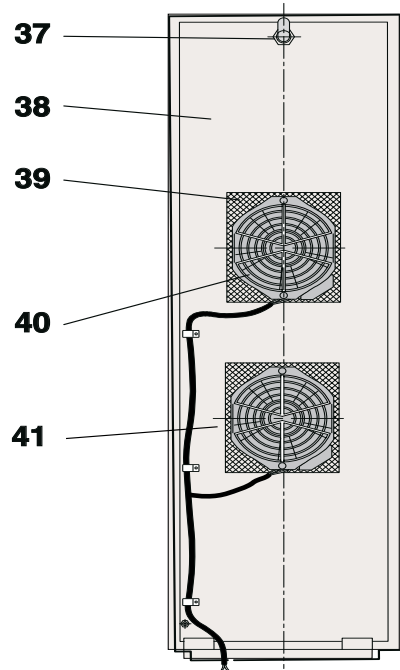

- | | |
|---------|---------------------------------|
| 37 | Lock |
| 38 | Hatch |
| 39 | Protective grid for air intakes |
| 40 - 41 | Cooling fans |

Fig. 2

1. DESCRIPTION AND TECHNICAL SPECIFICATIONS

TECHNICAL SPECIFICATIONS		
Power supply (Vac / Hz)	230 {+6% / -10%} / 50	
Absorbed power (W)	220	
Absorbed current (A)	1	
Type of oil	FAAC HP OIL	
Quantity of oil (litres)	~2,5	
Winding heat protection (°C)	120	
Anti-crushing system	standard by-pass valves	
Type of slow-down	Electronic	
Operating ambient temperature (°C)	-20 / +55	
Hood protective treatment	Cataphoresis	AISI 316 stainless-steel
Hood painting	Polyester RAL 2004	
Protection class	IP44	
Upright dimensions LxHxD (mm)	see Figs. 4 and 5	
Use frequency	100%	

TECHNICAL DETAILS OF 2800 rpm ELECTRIC MOTOR	
Power supply (Vac{+6% / -10%}/Hz)	230 / 50
Absorbed power (W)	200
Absorbed current (A)	1

2 ELECTRIC PREPARATIONS (standard system)

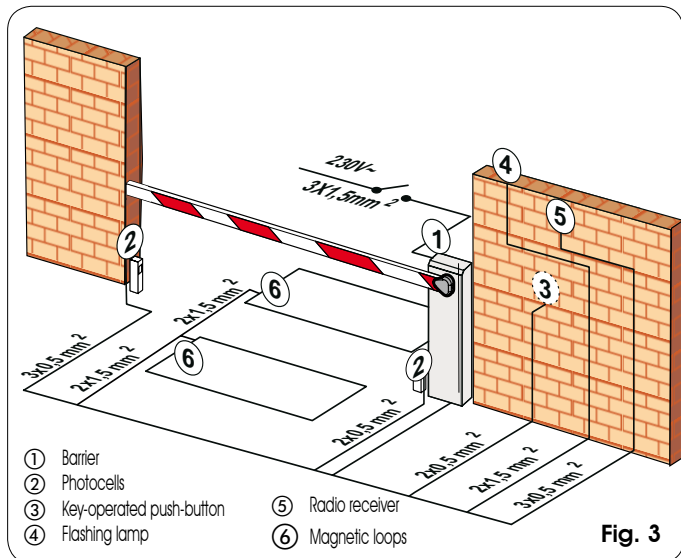

Fig. 3

To lay cables, use adequate rigid and/or flexible tubes. Always separate connection cables of low voltage accessories from power cables operating at 230V. To prevent any interference whatsoever, use separate sheaths.

3 BARRIER DIMENSIONS

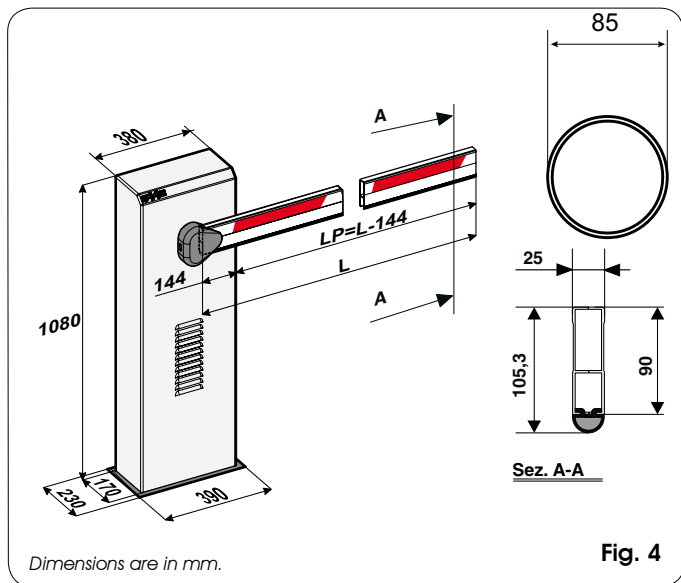

Fig. 4

4 INSTALLING THE AUTOMATED SYSTEM

4.1 PRELIMINARY CHECKS

To ensure safety and an efficiently operating automated system, make sure the following conditions are observed:

- When moving, the beam must not, on any account, meet any obstacles or overhead power cables.
- The soil must permit sufficient stability for the foundation plinth.
- There must be no pipes or electrical cables in the plinth excavation area.
- If the barrier body is exposed to passing vehicles, install, if possible, adequate means of protection against accidental impact.
- Check that an efficient earth socket is available for connecting the upright.

4.2 MASONRY FOR FOUNDATION PLATE

WALL THE FOUNDATION PLATE, TO ALLOW EASY ACCESS TO THE BARRIER HATCH.

- 1) Assemble the foundation plate as in fig.5. ref. ①
- 2) Make a foundation plinth as shown in fig.5 ref.② (with reference to clayey soil)
- 3) Wall the foundation plate as in fig.5. ref.② supplying one or more sheaths for routing electrical cables. Using a spirit level, check if the plate is perfectly level. Wait for the cement to set.

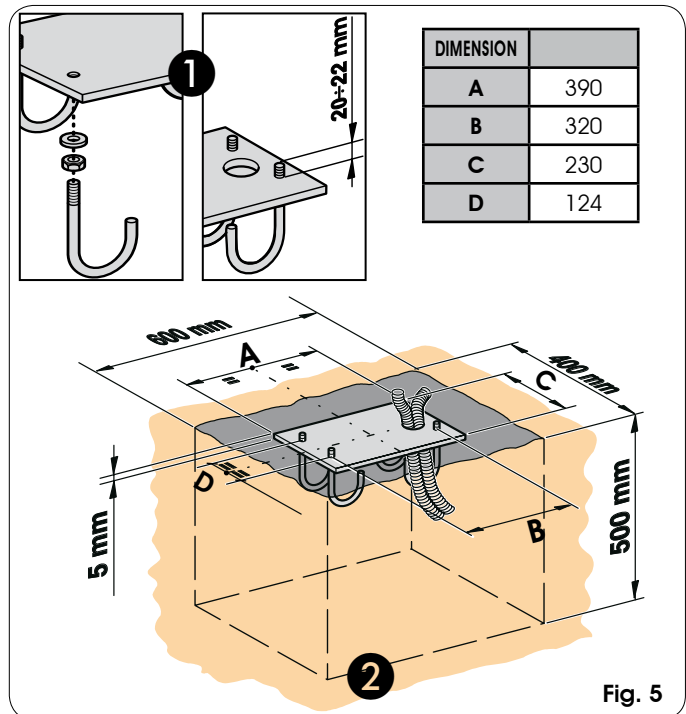

Fig. 5

4.3 MECHANICAL INSTALLATION

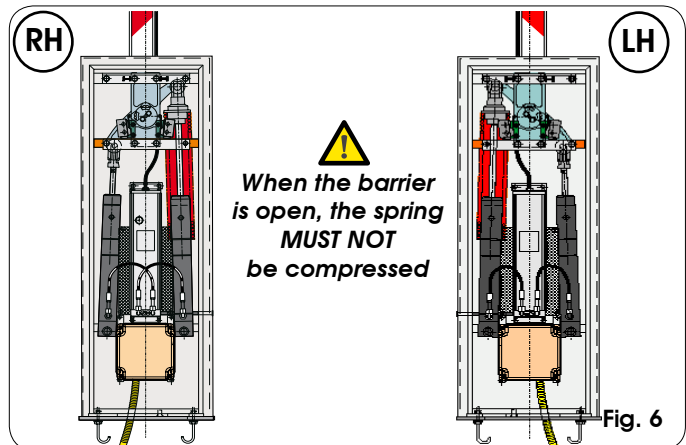

Fig. 6

- 1) Fasten the upright on the foundation plate using the four supplied nuts (fig. 7) and checking the configuration of the barrier as in figure 6. Remember that the hatch of the upright should normally face the building.
- 2) Set the operator for manual operation as described in chapter 6.
- 3) Remove and store the breather screws as shown in Fig.8.
- 4) Assemble the beam, using the supplied screws, as shown in figures 9, 10 and 11 (the rubber profile of the rectangular beam must face the closing direction (Fig 10) Ref 1.
- 5) Adjust the opening and closing travel limit mechanical stops as in fig.12 ref. ① and verify beam balancing following the instructions in paragraph 5.1.

ENGLISH

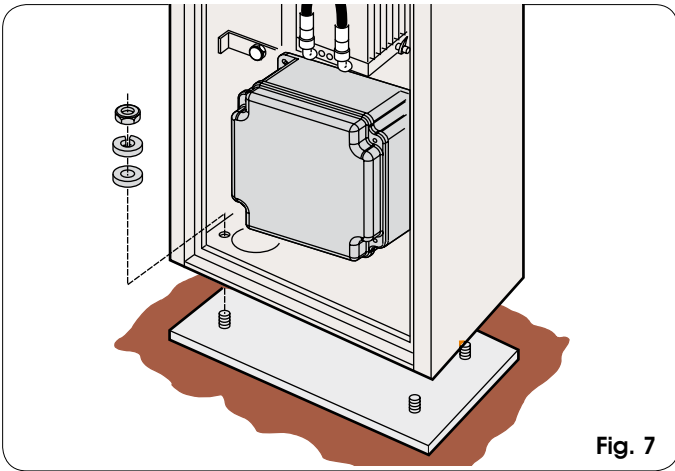

Fig. 7

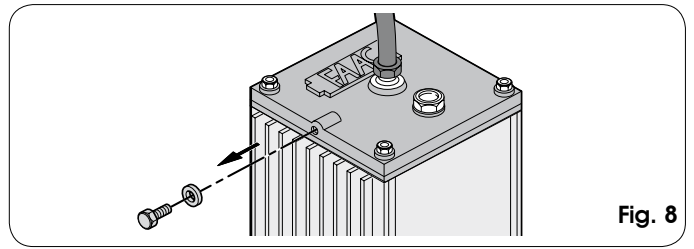

Fig. 8

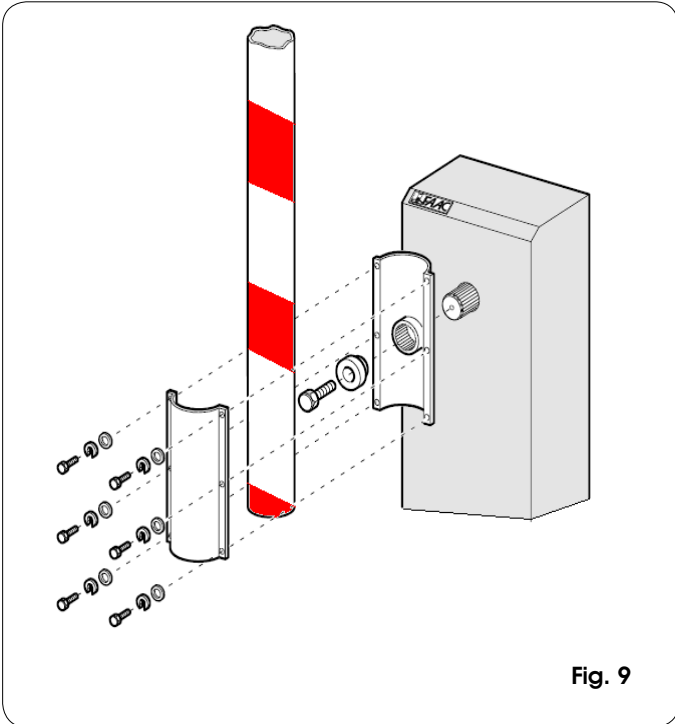

Fig. 9

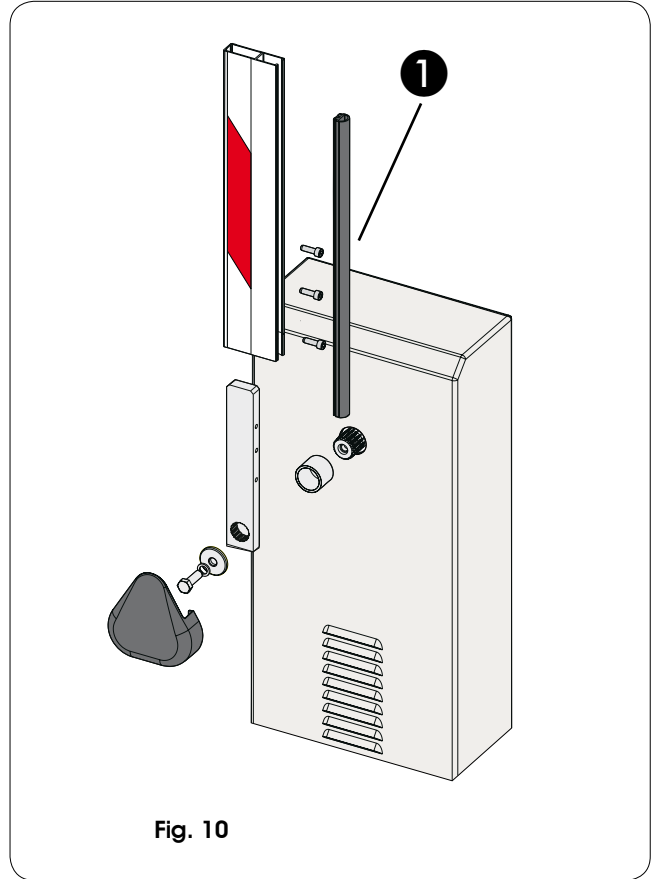

Fig. 10

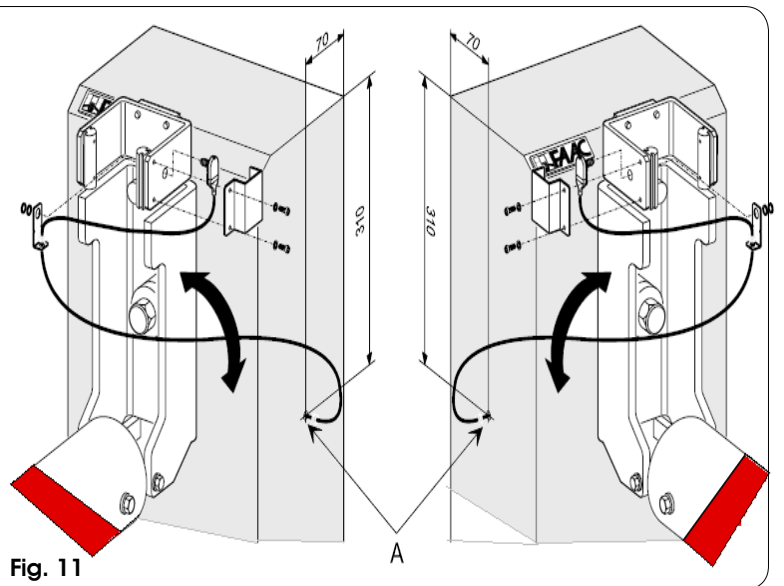
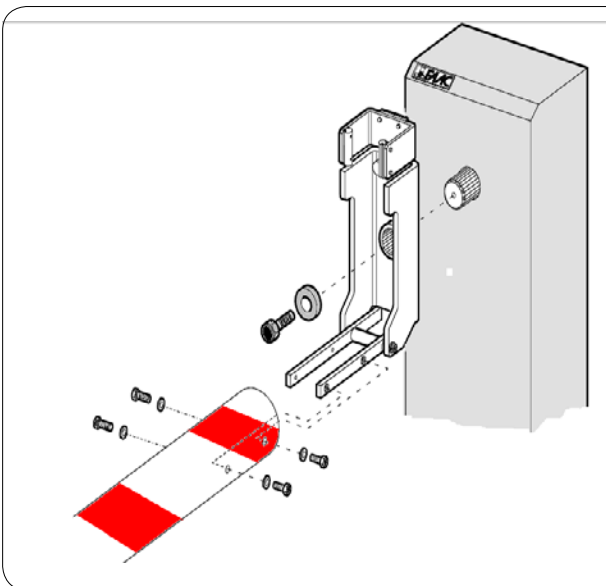

Fig. 11

5 START-UP

5.1 ADJUSTING THE BALANCING SPRING.

The barrier is supplied already balanced for the exact length of the beam indicated in the order.

(The barrier is balanced when, with the beam released, the beam stays idle in the 45° position)

For any fine tuning of barrier balancing, proceed as follows:

- 1) Make sure that the operator is released: see chapter 6.
- 2) If the barrier tends to close, turn the spring pre-loading ring-nut (Fig. 12 ref.②) clockwise; if it tends to open, turn it anti-clockwise.

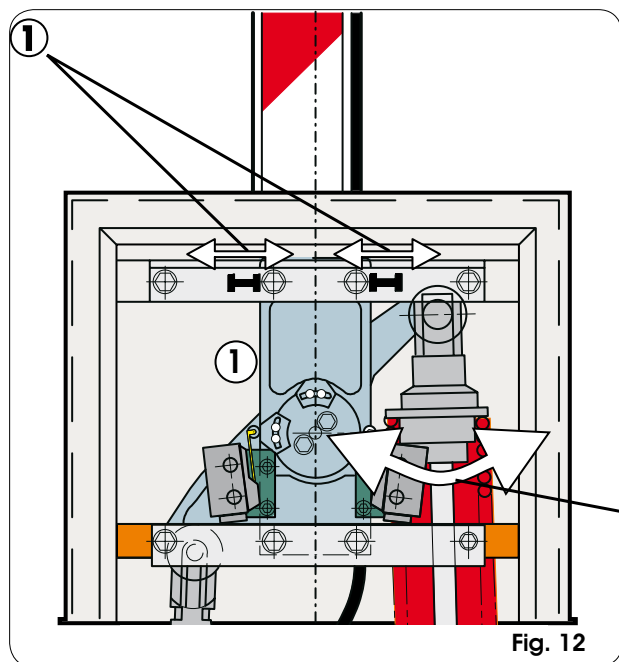

Fig. 12

5.2 CONNECTION TO CONTROL BOARD

⚠ IMPORTANT: Before attempting any work on the control unit (connections, maintenance, etc), always turn off power. For the electrical connections, refer to the dedicated instructions of the control unit.

👉 Observing the indications in fig.3, install the raceways and make the electrical connections from the control unit to the selected accessories. Always separate power cables from control and safety cables (push-button, receiver, photocells, etc.).

5.3 ADJUSTING THE TRANSMITTED TORQUE

To set the hydraulic system for controlling transmitted torque, turn the two by-pass screws (Fig. 13).

The red screw controls closing movement torque. The green screw controls opening movement torque. To increase torque, turn the screws clockwise. To reduce torque, turn the screws anti-clockwise. The deceleration of barrier 620 SR is factory-set. However, if small adjustments are required, turn the adjusting screws 111B and 33B in fig. 1.

Turn clockwise to increase deceleration, anticlockwise to reduce deceleration.

IMPORTANT: A 1/2 turn of the screw is sufficient for the adjustment.

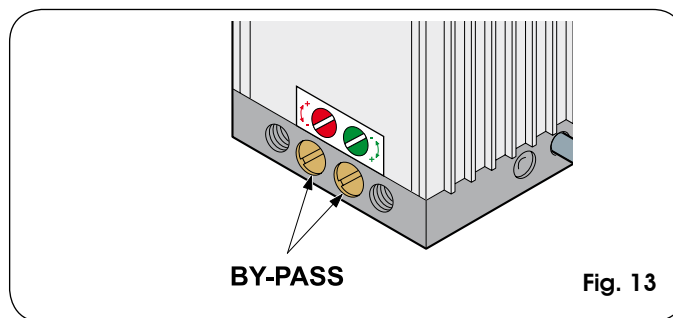

Fig. 13

5.4 ADJUSTING THE TRAVEL LIMIT SLOW DOWN

👉 For beams with a length of over 4 m, we advise you not to set too brief a slow down.

- 1) Adjust the cams of the travel limit device as shown in Fig. 14 ref. ① by loosening the two Allen screws. To increase the slow down angle, take the cam close to the relevant travel limit device. To reduce the slow down angle, take the cam away from the relevant travel limit device.
- 2) Set the slow down time of the control unit by adjusting the dedicated parameters.
- 3) Relock the system (see chap.7) and run a few operational tests to verify correct registration of the spring balancing travel limit devices and of the adjustment of transmitted force.

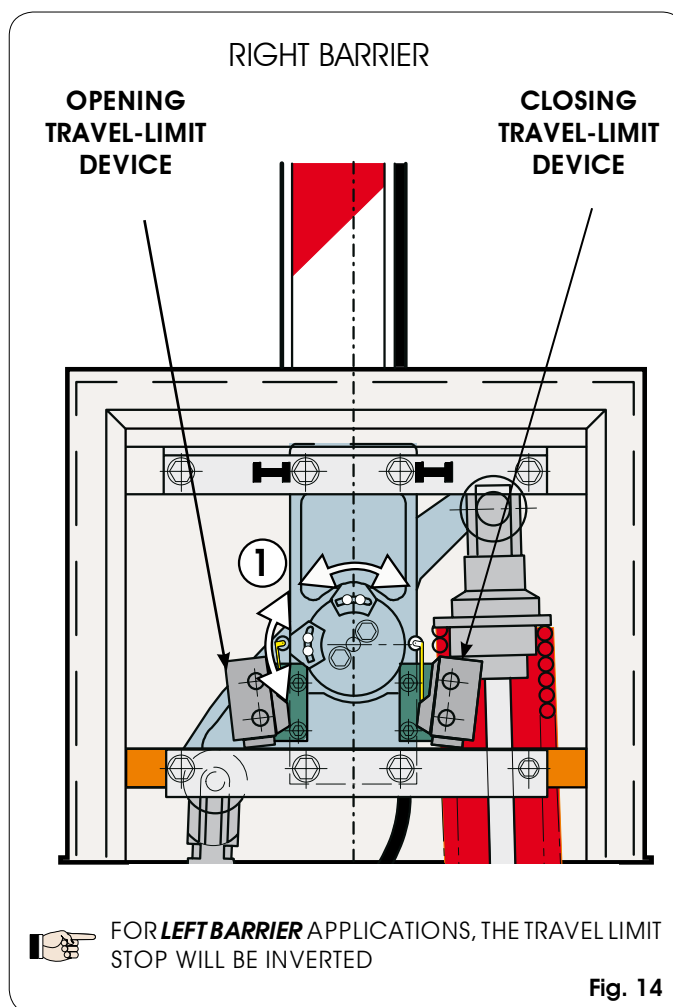

Fig. 14

👉 FOR **LEFT BARRIER** APPLICATIONS, THE TRAVEL LIMIT STOP WILL BE INVERTED

5.5 AUTOMATED SYSTEM TEST

After installation, apply the danger sticker to the top of the upright. Check operating efficiency of the automated system and all accessories connected to it.

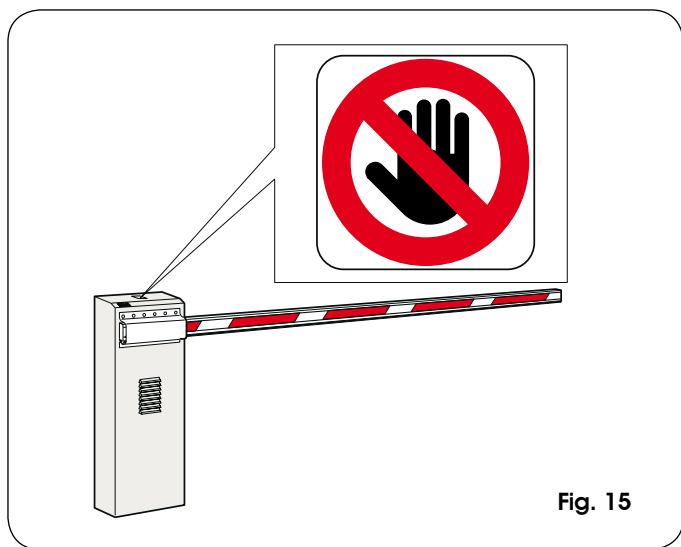



Fig. 15

 Hand over the "User manual" to the customer, as well as the documentation required by current laws, and illustrate the correct operation of the barrier, pointing out the potential danger zones.

6 MANUAL MODE OPERATION

If the barrier has to be moved manually due to a power cut or fault of the automated system, operate the release device with the supplied key.

The supplied release key can be triangular (Fig. 16 ref. ①) or customised (Fig. 16 ref. ②, optional).

- Insert the release key in the lock and turn it **anti-clockwise** through one complete turn as shown in Fig 16
- Open or close the barrier manually.

7 RESTORING NORMAL OPERATION MODE

To prevent an involuntary pulse from activating the barrier during the manoeuvre, cut power to the system before activating the locking system.

triangular release key (standard):

- turn the key **clockwise** until it stops and remove it (Fig. 16 ref. ①).

customised release key (optional):

- turn the key **clockwise** until the point where it can be removed (fig. 16 ref. ②).

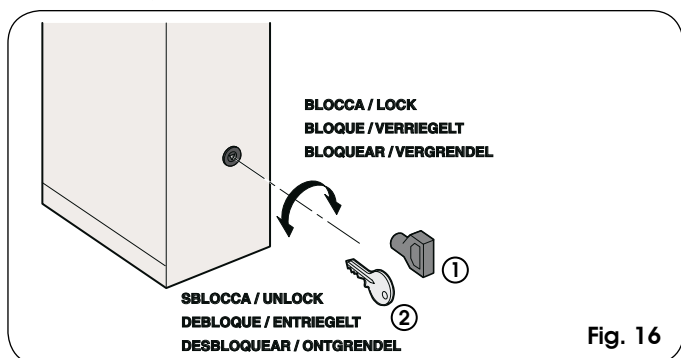

Fig. 16

8 MAINTENANCE

Below we indicate the procedures needed to ensure a suitable level of barrier efficiency and safety.

8.1 PRELIMINARY CHECKS

At the times of maintenance, perform a visual control of the status of the barrier and a general cleaning of the system.

Check the efficiency of the release devices and any illuminating devices.

8.2 CHECKING OF SAFETY DEVICES

Check the correct operation of the anti-crushing system (regulation of by-pass screws par. 5.1), also check the correct regulation of the balancing spring (par. 5.3).

8.3 TOPPING UP OIL

Periodically check the quantity of oil inside the tank.

An annual check is sufficient for low to medium use frequency; for heavier duty, check every 6 months.

The level must not drop below the notch of the control stick (Fig. 17 ref ①).

To top-up, unscrew the filling plug (fig.17) and pour in oil up to the correct level.

Use FAAC HP OIL and no other.

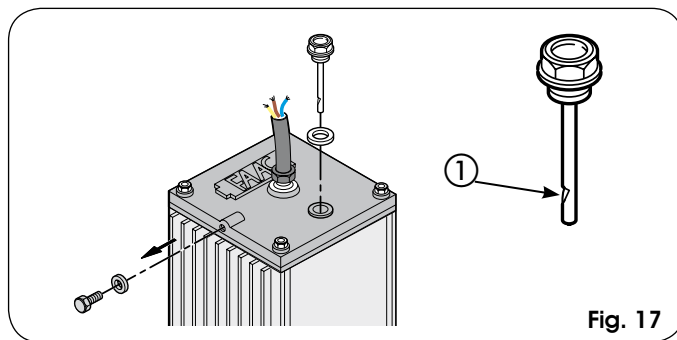

Fig. 17

8.4 BLEEDING OPERATION

If beam movement is incorrect, air must be bled from the hydraulic system. Procedure:

- 1) Make sure that the breather screw has been eliminated (Fig.8)
- 2) Activate the beam electrically:
 - during opening, slightly loosen and re-screw the bleed screw of the piston with the balancing spring (Fig. 1 ref. 33).
 - during closure, slightly loosen and re-screw the bleed screw of the piston without the balancing spring (fig. 1 ref. 11).
- 3) If necessary, repeat the operation several times, until you obtain correct beam movement.

9 REPAIRS

For any repairs, contact FAAC's authorised Repair Centres.

10 CHANGING THE RH (LH) VERSION OF THE BARRIER INTO THE LH (RH) VERSION

Procedure for converting an RH (LH) version barrier into an LH (RH) version:

1. Release the barrier as shown in Chapter 6.
2. Position the beam in the opening position and remove it from the pocket as shown in Figs. 9, 10 or 11 .
3. Re-lock the barrier as shown in Chapter 7.
4. Screw the breather screw on the control unit (Fig. 8).
5. Fully loosen the spring adjustment ring-nut (Fig.18 ref. ④).
6. Detach the feed pipes (Fig.18 ref.③, and ⑥) from the two pistons and plug the unions.
7. Remove the two pistons (Fig. 18 ref. ② and ⑤) from the upper and lower fittings and reverse their position, taking the rocker (Fig.18 ref. ①) against the opening travel limit mechanical stop.
8. Remove the pinion pocket and re-install it to set the barrier at opening, as in Fig. 18.
9. Fit the feed pipes as shown in Fig. 18, according to the configuration of the barrier (RH or LH).
10. Reverse the travel limit connectors on the control unit.
11. Remove the breather screw from the control unit (Fig.8) and carry out the air bleed operations as indicated in paragraph 8.2.
12. Check the balance of the spring as indicated in paragraph 5.1

ENGLISH

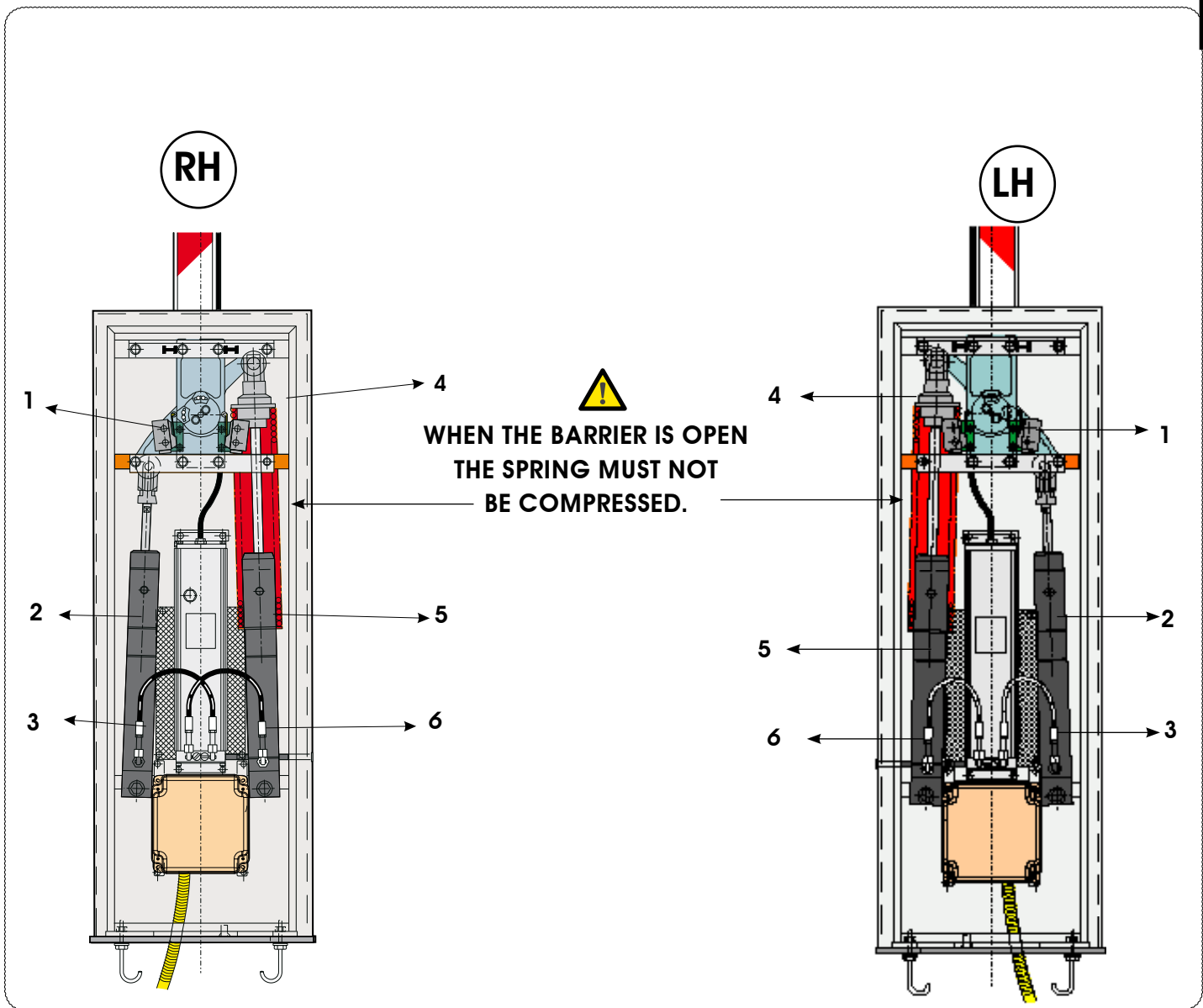

Fig. 18

11 AVAILABLE ACCESSORIES

11.1 ANTI-VANDAL VALVE (Fig. 19a)

It protects the hydraulic system if the beam is forced.

11.2 AUTOMATIC EMERGENCY RELEASE (Fig. 19b)

During a power cut, the automatic emergency release allows you to manually lift the beam without accessing the release lever of the hydraulic control unit. A hydraulic system guarantees that the beam is stopped in the opening position.

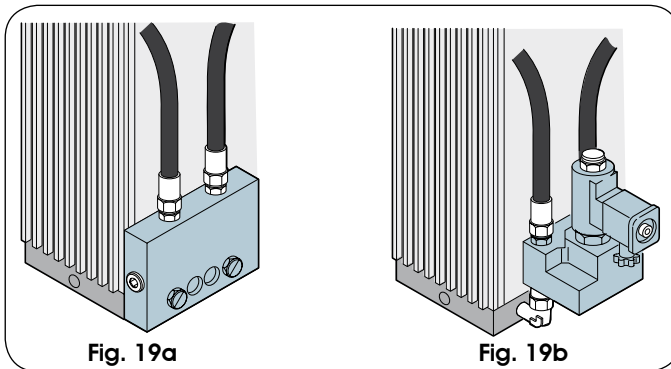

Fig. 19a

Fig. 19b

11.3 FORK SUPPORT

The fork has two functions:

- it prevents the beam, when closed, from bending and splitting if its end is stressed by extraneous forces.
- it allows the beam to rest when closed and thus prevents the profile bending downward

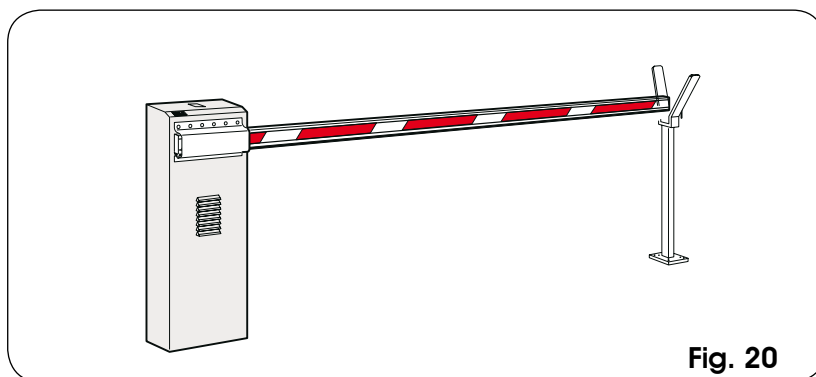

Fig. 20

To position the fork support foundation plate, refer to fig.21 where:

P1 = barrier foundation plate

P2 = fork support foundation plate

L = beam length (in mm)

A = distance between foundation plates

NB: Dimensions are in mm.

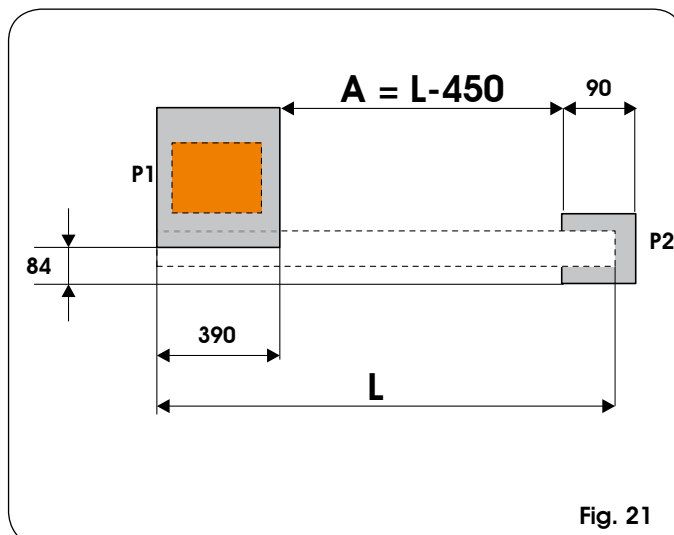

Fig. 21