

# GEO 05

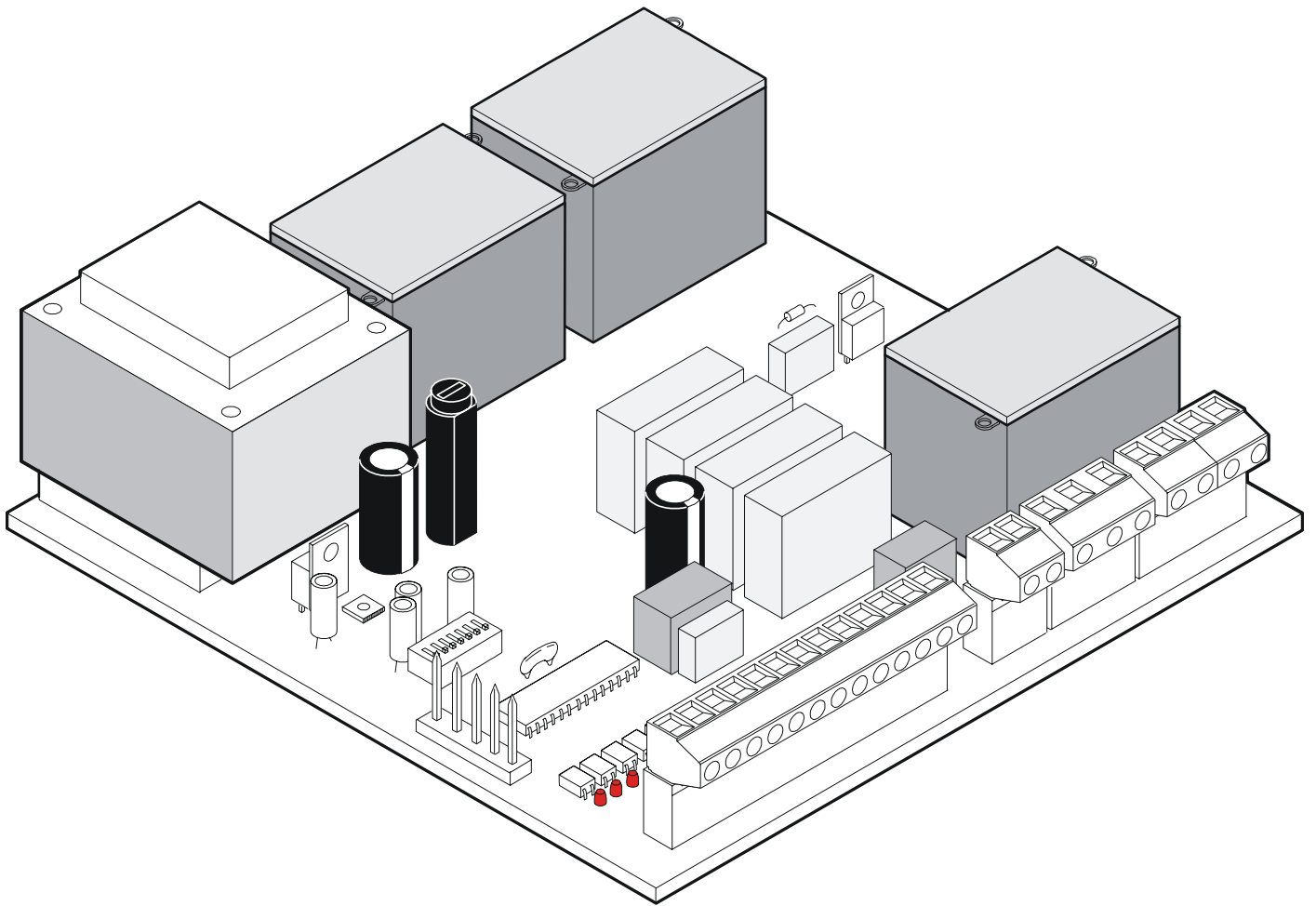

# GENIUS®

**COMPANY  
WITH QUALITY SYSTEM  
CERTIFIED BY DNV  
= UNI EN ISO 9001/2000=**



## AVVERTENZE PER L'INSTALLATORE

### OBBLIGHI GENERALI PER LA SICUREZZA

- 1) ATTENZIONE! È importante per la sicurezza delle persone seguire attentamente tutta l'istruzione. Una errata installazione o un errato uso del prodotto può portare a gravi danni alle persone.**
- 2) Leggere attentamente le istruzioni prima di iniziare l'installazione del prodotto.
- 3) I materiali dell'imballaggio (plastica, polistirolo, ecc.) non devono essere lasciati alla portata dei bambini in quanto potenziali fonti di pericolo.
- 4) Conservare le istruzioni per riferimenti futuri.
- 5) Questo prodotto è stato progettato e costruito esclusivamente per l'utilizzo indicato in questa documentazione. Qualsiasi altro utilizzo non espressamente indicato potrebbe pregiudicare l'integrità del prodotto e/o rappresentare fonte di pericolo.
- 6) GENIUS declina qualsiasi responsabilità derivata dall'uso improprio o diverso da quello per cui l'automatismo è destinato.
- 7) Non installare l'apparecchio in atmosfera esplosiva: la presenza di gas o fumi infiammabili costituisce un grave pericolo per la sicurezza.
- 8) Gli elementi costruttivi meccanici devono essere in accordo con quanto stabilito dalle Norme EN 12604 e EN 12605.  
Per i Paesi extra-CEE, oltre ai riferimenti normativi nazionali, per ottenere un livello di sicurezza adeguato, devono essere seguite le Norme sopra riportate.
- 9) GENIUS non è responsabile dell'inosservanza della Buona Tecnica nella costruzione delle chiusure da motorizzare, nonché delle deformazioni che dovessero intervenire nell'utilizzo.
- 10) L'installazione deve essere effettuata nell'osservanza delle Norme EN 12453 e EN 12445. Il livello di sicurezza dell'automazione deve essere C+D.
- 11) Prima di effettuare qualsiasi intervento sull'impianto, togliere l'alimentazione elettrica e scollegare le batterie.
- 12) Prevedere sulla rete di alimentazione dell'automazione un interruttore onnipolare con distanza d'apertura dei contatti uguale o superiore a 3 mm. È consigliabile l'uso di un magnetotermico da 6A con interruzione onnipolare.
- 13) Verificare che a monte dell'impianto vi sia un interruttore differenziale con soglia da 0,03 A.
- 14) Verificare che l'impianto di terra sia realizzato a regola d'arte e collegarvi le parti metalliche della chiusura.
- 15) L'automazione dispone di una sicurezza intrinseca antischiacciamento costituita da un controllo di coppia. E' comunque necessario verificarne la soglia di intervento secondo quanto previsto dalle Norme indicate al punto 10.
- 16) I dispositivi di sicurezza (norma EN 12978) permettono di proteggere eventuali aree di pericolo da **Rischi meccanici di movimento**, come ad Es. schiacciamento, convogliamento, cesoiamento.
- 17) Per ogni impianto è consigliato l'utilizzo di almeno una segnalazione luminosa nonché di un cartello di segnalazione fissato adeguatamente sulla struttura dell'infisso, oltre ai dispositivi citati al punto "16".
- 18) GENIUS declina ogni responsabilità ai fini della sicurezza e del buon funzionamento dell'automazione, in caso vengano utilizzati componenti dell'impianto non di produzione GENIUS.
- 19) Per la manutenzione utilizzare esclusivamente parti originali GENIUS.
- 20) Non eseguire alcuna modifica sui componenti facenti parte del sistema d'automazione.
- 21) L'installatore deve fornire tutte le informazioni relative al funzionamento manuale del sistema in caso di emergenza e consegnare all'Utente utilizzatore dell'impianto il libretto d'avvertenze allegato al prodotto.
- 22) Non permettere ai bambini o persone di sostare nelle vicinanze del prodotto durante il funzionamento.
- 23) Tenere fuori dalla portata dei bambini radiocomandi o qualsiasi altro datore di impulso, per evitare che l'automazione possa essere azionata involontariamente.
- 24) Il transito tra le ante deve avvenire solo a cancello completamente aperto.
- 25) L'Utente utilizzatore deve astenersi da qualsiasi tentativo di riparazione o d'intervento diretto e rivolgersi solo a personale qualificato.
- 26) Tutto quello che non è previsto espressamente in queste istruzioni non è permesso**

## IMPORTANT NOTICE FOR THE INSTALLER

### GENERAL SAFETY REGULATIONS

- 1) ATTENTION! To ensure the safety of people, it is important that you read all the following instructions. Incorrect installation or incorrect use of the product could cause serious harm to people.**
- 2) Carefully read the instructions before beginning to install the product.
- 3) Do not leave packing materials (plastic, polystyrene, etc.) within reach of children as such materials are potential sources of danger.
- 4) Store these instructions for future reference.
- 5) This product was designed and built strictly for the use indicated in this documentation. Any other use, not expressly indicated here, could compromise the good condition/operation of the product and/or be a source of danger.
- 6) GENIUS declines all liability caused by improper use or use other than that for which the automated system was intended.
- 7) Do not install the equipment in an explosive atmosphere: the presence of inflammable gas or fumes is a serious danger to safety.

- 8) The mechanical parts must conform to the provisions of Standards EN 12604 and EN 12605.

For non-EU countries, to obtain an adequate level of safety, the Standards mentioned above must be observed, in addition to national legal regulations.

- 9) GENIUS is not responsible for failure to observe Good Technique in the construction of the closing elements to be motorised, or for any deformation that may occur during use.
- 10) The installation must conform to Standards EN 12453 and EN 12445. The safety level of the automated system must be C+D.
- 11) Before attempting any job on the system, cut out electrical power and disconnect the batteries.
- 12) The mains power supply of the automated system must be fitted with an all-pole switch with contact opening distance of 3mm or greater. Use of a 6A thermal breaker with all-pole circuit break is recommended.
- 13) Make sure that a differential switch with threshold of 0.03 A is fitted upstream of the system.
- 14) Make sure that the earthing system is perfectly constructed, and connect metal parts of the means of the closure to it.
- 15) The automated system is supplied with an intrinsic anti-crushing safety device consisting of a torque control. Nevertheless, its tripping threshold must be checked as specified in the Standards indicated at point 10.
- 16) The safety devices (EN 12978 standard) protect any danger areas against **mechanical movement Risks**, such as crushing, dragging, and shearing.
- 17) Use of at least one indicator-light is recommended for every system, as well as a warning sign adequately secured to the frame structure, in addition to the devices mentioned at point "16".
- 18) GENIUS declines all liability as concerns safety and efficient operation of the automated system, if system components not produced by GENIUS are used.
- 19) For maintenance, strictly use original parts by GENIUS.
- 20) Do not in any way modify the components of the automated system.
- 21) The installer shall supply all information concerning manual operation of the system in case of an emergency, and shall hand over to the user the warnings handbook supplied with the product.
- 22) Do not allow children or adults to stay near the product while it is operating.
- 23) Keep remote controls or other pulse generators away from children, to prevent the automated system from being activated involuntarily.
- 24) Transit through the leaves is allowed only when the gate is fully open.
- 25) The user must not attempt any kind of repair or direct action whatever and contact qualified personnel only.
- 26) Anything not expressly specified in these instructions is not permitted.**

## CONSIGNES POUR L'INSTALLATEUR

### RÈGLES DE SÉCURITÉ

- 1) ATTENTION! Il est important, pour la sécurité des personnes, de suivre à la lettre toutes les instructions. Une installation erronée ou un usage erroné du produit peut entraîner de graves conséquences pour les personnes.**
- 2) Lire attentivement les instructions avant d'installer le produit.
- 3) Les matériaux d'emballage (matière plastique, polystyrène, etc.) ne doivent pas être laissés à la portée des enfants car ils constituent des sources potentielles de danger.
- 4) Conserver les instructions pour les références futures.
- 5) Ce produit a été conçu et construit exclusivement pour l'usage indiqué dans cette documentation. Toute autre utilisation non expressément indiquée pourrait compromettre l'intégrité du produit et/ou représenter une source de danger.
- 6) GENIUS décline toute responsabilité qui dériverait d'usage improprie ou différent de celui auquel l'automatisme est destiné.
- 7) Ne pas installer l'appareil dans une atmosphère explosive: la présence de gaz ou de fumées inflammables constitue un grave danger pour la sécurité.
- 8) Les composants mécaniques doivent répondre aux prescriptions des Normes EN 12604 et EN 12605.  
Pour les Pays extra-CEE, l'obtention d'un niveau de sécurité approprié exige non seulement le respect des normes nationales, mais également le respect des Normes susmentionnées.
- 9) GENIUS n'est pas responsable du non-respect de la Bonne Technique dans la construction des fermetures à motoriser, ni des déformations qui pourraient intervenir lors de l'utilisation.
- 10) L'installation doit être effectuée conformément aux Normes EN 12453 et EN 12445. Le niveau de sécurité de l'automatisme doit être C+D.
- 11) Couper l'alimentation électrique et déconnecter la batterie avant toute intervention sur l'installation.
- 12) Prévoir, sur le secteur d'alimentation de l'automatisme, un interrupteur onnipolaire avec une distance d'ouverture des contacts égale ou supérieure à 3 mm. On recommande d'utiliser un magnétothermique de 6A avec interruption onnipolaire.
- 13) Vérifier qu'il y ait, en amont de l'installation, un interrupteur différentiel avec un seuil de 0,03 A.
- 14) Vérifier que la mise à terre est réalisée selon les règles de l'art et y connecter les pièces métalliques de la fermeture.
- 15) L'automatisme dispose d'une sécurité intrinsèque anti-écrasement, formée d'un contrôle du couple. Il est toutefois nécessaire d'en vérifier le seuil d'intervention suivant les prescriptions des Normes indiquées au point 10.

# CONTENTS

<b>CE DECLARATION OF CONFORMITY</b>	<b>pag.6</b>
<b>ELECTRICAL CONNECTIONS WITH 400V 3ph</b>	<b>pag.7</b>
<b>TECHNICAL SPECIFICATIONS</b>	<b>pag.7</b>
<b>DESCRIPTION</b>	<b>pag.8</b>
<b>PROGRAMMING</b>	<b>pag.9</b>
<b>FAULT CONDITIONS</b>	<b>pag.10</b>
<b>LIMIT SENSORS CONNECTION CHECK</b>	<b>pag.10</b>
<b>ELECTRICAL CONNECTIONS WITH 230V 3ph</b>	<b>pag.10</b>
<b>NOTES</b>	<b>pag.10</b>

ENGLISH

## CE DECLARATION OF CONFORMITY

**Manufacturer :** GENIUS S.p.A.

**Address:** Via Padre Elzi, 32  
24050 - Grassobbio  
BERGAMO - ITALY

Declares that: Electronic control unit **GEO 05**

- conforms to the essential safety requirements of the following directives:

73/23/EEC and subsequent amendment 93/68/EEC.  
89/336/EEC and subsequent amendment 92/31/EEC and 93/68/EEC

**Additional information:**

This product underwent a test in a typical, uniform configuration (all products manufactured by GENIUS S.r.l.).

Grassobbio, 03 May 2004

The Managing Director  
D. Gianantoni



1. TECHNICAL SPECIFICATIONS

TABLE 1: TECHNICAL SPECIFICATIONS

Power supply	230V 3ph+N (+6 -10 %) 50Hz 400V 3ph (+6 -10 %) 50Hz
Motor max load	1,3 KW
Accessories power supply	24 Vdc
Accessories max load	500 mA
Warning light power supply	24V~ (5W max)
Temperature range	- 20°C + 55°C
Fuses	transformer primary winding accessories
Quick-fit plugs	for receivers
Inputs	Open / Partial open / Stop / Closure safety devices / Limit-sensors
Outputs	warning light / flashlight / motor / power supply to 24Vdc accessories
Programming	pause time (5-10-15-30-60-120-180 sec.) / logics A1- A2-S1-S2-E1-E2-B-C / pre- flashing
Motor braking	fixed
Safety timing	255 sec.

1.1. LAY-OUT

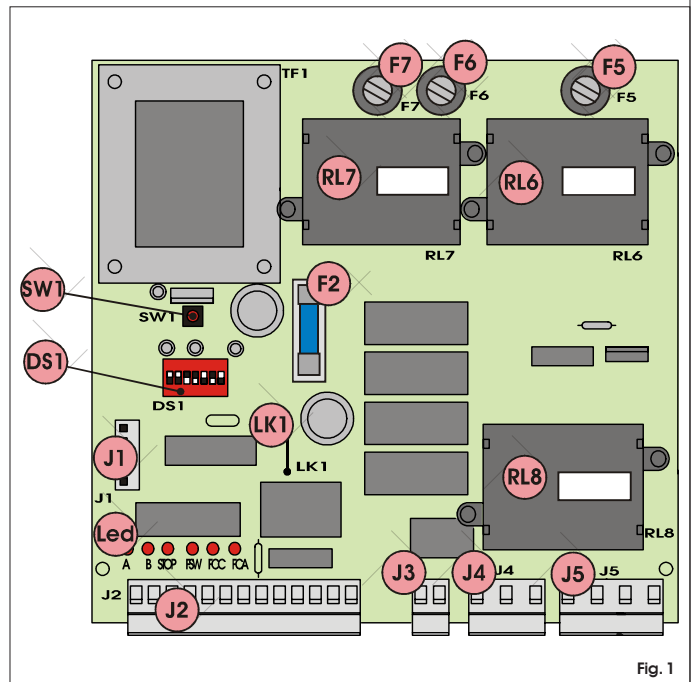

ENGLISH

TABLE 2: COMPONENTS

F5-F6-F7	Fuse 6.3x62 5A/250V rapid (transformer)	J3	Flashlight output terminal board (230V~ max 60W)
F2	Fuse 5x20 1,6A/250V rapid (accessories)	J4	Motor output terminal board
SW1	RESET push-button	J5	Line power supply input terminal board
DS1	Programming micrositches	LK1	Bridge for warning light free contact
Led	Input status signalling LEDs	RL6-7	Motor relay
J1	Quick-fit plug for receivers	RL8	Braking relay
J2	Low voltage terminal board for inputs/accessories		

2. ELECTRICAL CONNECTIONS WITH 400V 3ph (N.B.: for connection to 230 V 3ph, see Chapter 8)

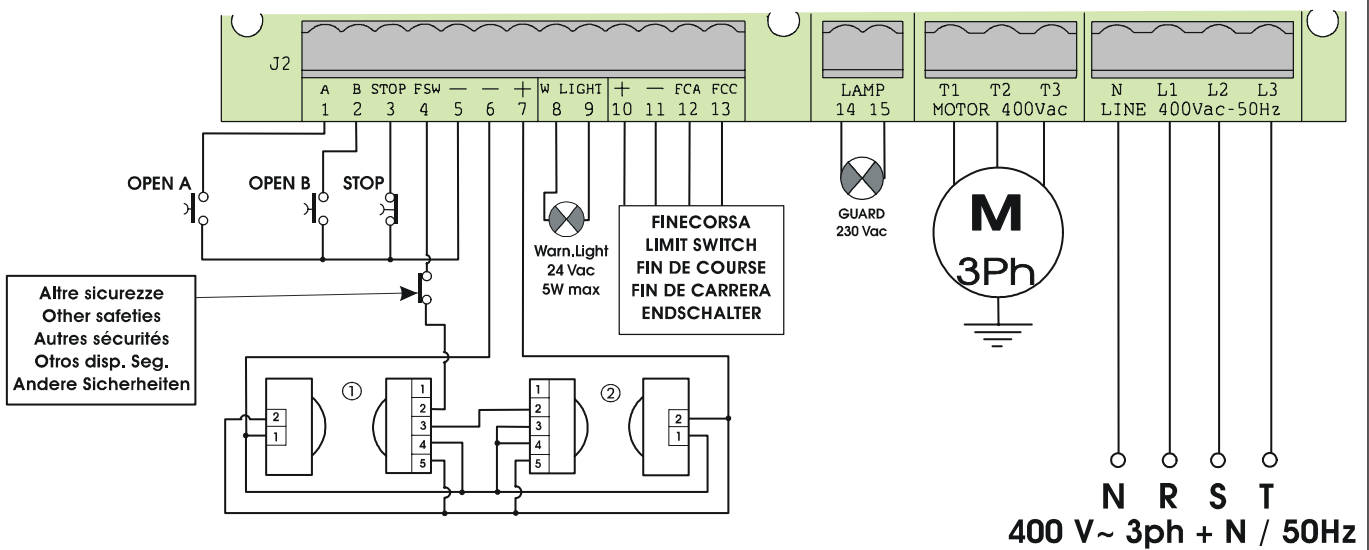

Fig. 2

➔ Before attempting any work on the card (connections, programming, maintenance), always turn off power.  
Warning: If plugs J3 and J4 are disconnected, high voltage may be present on the flashlight and motor outputs.

Observe points 10, 11, 12, and 14 of the GENERAL SAFETY RULES. Always separate power cables from control and safety cables (push-button receiver, photocells, etc.). To prevent any electrical noise whatever, use separate sheaths.

### 3. DESCRIPTION

#### 3.1. J1 PLUG

Insert the receiver card in the block connector J1 (Fig. 2) as indicated in Fig. 3.  
For programming the receiver card, consult the individual instructions.

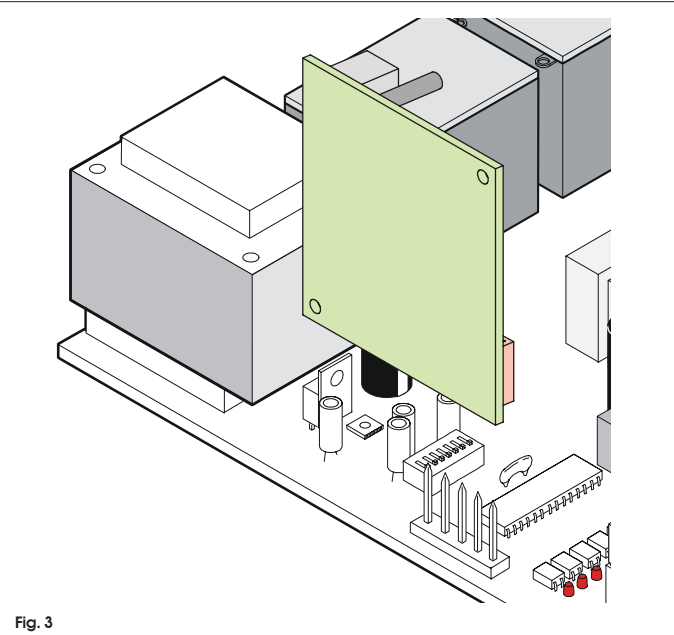

Fig. 3

#### 3.2. TERMINAL BOARD J2 (low voltage)

##### 1 = OPEN A (N.O.) – Total opening

This is any pulse generator with N.O. contact which, when activated, produces a gate opening movement. In A, E and S logics, it commands both opening and closing. To install several Open A devices, connect N.O. contacts in parallel.

##### 2 = OPEN B (N.O.) – Opening for pedestrians / Closing

This is any pulse generator with N.O. contact which, when activated in logics A, E and S, produces a gate opening movement for pedestrians. In B and C logics, it commands a closing movement.

To install several Open B devices, connect N.O. contacts in parallel.

##### 3 = STOP command (N.C.)

This is any device (e.g. a push-button) which, by opening a contact, stops gate movement.

To install several stop devices, connect the N.C. contacts in series.

➔ If Stop devices are not connected, link the input to the common contact (terminal 5) via a jumper.

##### 4 = FSW closing safety devices contact (N.C.)

Safety devices are all devices (photocells, sensitive edges, magnetic coils) with N.C. contact, which, if there is an obstacle in the area they protect, operate to interrupt gate movement. The purpose of the closing safety devices is to protect the gate movement area during closing.

If the safety devices are tripped during closure, gate movement is reversed, whereas they have no effect during opening. If used when the gate is open or pausing, closing safety devices prevent its closing.

To install several safety devices, connect the N.C. contacts in series.

➔ If closing safety devices are not connected, link this input to the common contact (terminal 5) via a jumper.

##### 5 = Common contact for commands

##### 6 = Negative of accessories power supply

##### 7 = 24 Vdc (+) power supply for accessories

Max load of accessories is 500 mA. To calculate absorption values, refer to the instructions for individual accessories.

##### 9 = Warning light output (24 Vac)

The maximum load of the warning light is 5 W. For instructions on operation of the warning light, consult microswitch programming.

➔ If you cut out jumper LK1, you obtain a voltage free contact between terminals 8 and 9 (see fig. 6).

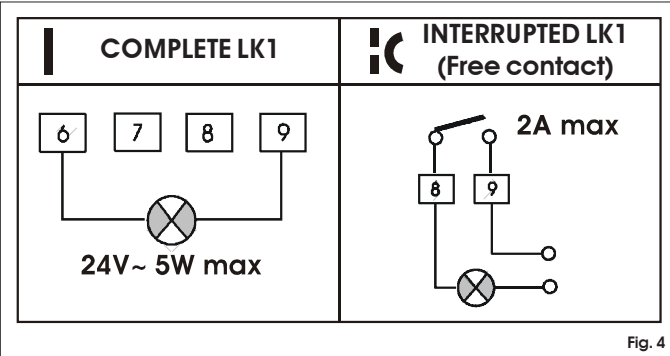

Fig. 4

##### 10 = 24 Vdc (+) power supply for inductive limit switch

##### 11 = Limit switch common contact

##### 12 = Opening limit switch (N.O.)

##### 13 = Closing limit switch (N.O.)

#### 3.3. TERMINAL BOARD J3 (high voltage)

Terminal board for connecting flashlight (max 60W).

#### 3.4. TERMINAL BOARD J4 (high voltage)

Terminal board for connection of motor.

#### 3.5. TERMINAL BOARD J5 (high voltage)

Terminal board for supplying power of 400V 3ph + Neutral - 50 Hz (see fig.2) or 230V 3ph - 50 Hz (see fig.5).

#### 3.6. SIGNALLING LEDs

6 LEDs are fitted on the card, indicating status of terminal board inputs:

**Led lighted** = contact closed

**Led off** = contact open

TABLE 3: STATUS OF LEDs

LED	LIGHTED	OFF
OPEN A	command active	<b>command inactive</b>
OPEN B	command active	<b>command inactive</b>
STOP	<b>command inactive</b>	command active
FSW	<b>safety devices not operating</b>	safety devices operating
FCC	closing limit sensor free	<b>closing limit sensor engaged</b>
FCA	<b>opening limit sensor free</b>	opening limit sensor engaged

NB.: The status of the LEDs while the gate is at rest are shown in bold.

## 4. PROGRAMMING

To program operation of automation, use the microswitches as shown below.

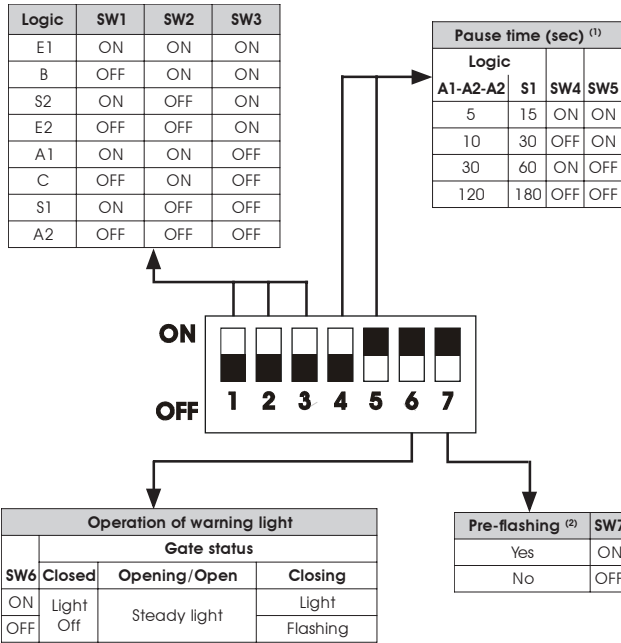

- (1) Pause times include pre-flashing if any  
 (2) Pre-flashing begins 5" before every movement.

➔ You must press the RESET push-button after every programming job.

### Function logics

The following are available:

A1/A2 = "Automatic"                      S1/S2 = "Safety"  
 E1/E2/B = "Semi-automatic"            C = "Dead man"

Operation of automation in the different logics is indicated in Tables 4-5-6-7-8-9-10-11.

### Pause time

Pause time is waiting time in open position before re-closing when an automatic logic was selected.  
 Pause times include pre-flashing if any

### Operation of warning light

Used to change the appearance of the warning light at closing by making it flash.

### Pre-flashing

Flashlight pre-flashing time of 5 sec before any movement can be selected. This warns anyone near the gate that it is about to move.

TABLE 4 LOGIC A1 (AUTOMATIC)

LOGIC A1	PULSES		
GATE STATUS	OPEN A - OPEN B <sup>(1)</sup>	STOP	SAFETY DEVICES
Closed	opens and closes after pause time <sup>(2)</sup>	no effect	no effect
Open on pause	re-closes after 5" <sup>(3)</sup>	stops the count	freezes pause until disengagement
Closing	reverses motion	stops	reverses motion
Opening	no effect	stops	no effect
Stopped	re-closes <sup>(2)</sup>	no effect	no effect

TABLE 5 LOGIC A2 (AUTOMATIC PLUS)

LOGIC A2	PULSES		
GATE STATUS	OPEN A - OPEN B <sup>(1)</sup>	STOP	SAFETY DEVICES
Closed	opens and closes after pause time <sup>(2)</sup>	no effect	no effect
Open on pause	re-closes after 5" <sup>(3)</sup>	stops the count	when disengaged, re-closes after 5"
Closing	reverses motion	stops	stops and reverses at disengagement <sup>(2)</sup>
Opening	no effect	stops	no effect
Stopped	re-closes <sup>(2)</sup>	no effect	no effect

TABLE 6 LOGIC S1 (SAFETY)

LOGIC S1	PULSES		
GATE STATUS	OPEN A - OPEN B <sup>(1)</sup>	STOP	SAFETY DEVICES
Closed	opens and closes after pause time <sup>(2)</sup>	no effect	no effect
Open on pause	closes immediately <sup>(2-3)</sup>	stops the count	when disengaged, re-closes after 5"
Closing	reverses motion	stops	reverses motion
Opening	reverses motion	stops	no effect
Stopped	re-closes <sup>(2)</sup>	no effect	no effect

TABLE 7 LOGIC S2 (SAFETY PLUS)

LOGIC S2	PULSES		
GATE STATUS	OPEN A - OPEN B <sup>(1)</sup>	STOP	SAFETY DEVICES
Closed	opens and closes after pause time <sup>(2)</sup>	no effect	no effect
Open on pause	closes immediately <sup>(2-3)</sup>	stops the count	freezes pause until disengagement
Closing	reverses motion	stops	stops and reverses at disengagement <sup>(2)</sup>
Opening	reverses motion	stops	no effect
Stopped	re-closes <sup>(2)</sup>	no effect	no effect

TABLE 8 LOGIC E1 (SEMI-AUTOMATIC)

LOGIC E1	PULSES		
STATO CANCELO	OPEN A - OPEN B <sup>(1)</sup>	STOP	SAFETY DEVICES
Closed	opens <sup>(2)</sup>	no effect	no effect
Open on pause	re-closes <sup>(2)</sup>	no effect	no effect
Closing	reverses motion	stops	reverses motion
Opening	stops	stops	no effect
Stopped	re-closes (when safety devices engaged, it re-opens) <sup>(2)</sup>	no effect	no effect

TABLE 9 LOGIC E2 (SEMI-AUTOMATIC PLUS)

LOGIC E2	PULSES		
GATE STATUS	OPEN A - OPEN B <sup>(1)</sup>	STOP	SICUREZZE
Closed	opens <sup>(2)</sup>	no effect	no effect
Open on pause	re-closes <sup>(2)</sup>	no effect	no effect
Closing	reverses motion	stops	stops and reverses at disengagement <sup>(2)</sup>
Opening	stops	stops	no effect
Stopped	re-closes (when safety devices engaged, it re-opens) <sup>(2)</sup>	no effect	no effect

TABLE 10 LOGIC B (SEMI-AUTOMATIC)

LOGIC B	PULSES			
GATE STATUS	OPEN A	OPEN B <sup>(4)</sup>	SAFETY DEVICES	STOP
Closed	opens <sup>(2)</sup>	no effect	no effect	no effect
Open on pause	no effect	closes <sup>(2)</sup>	prevents closing	no effect
Closing	no effect	no effect	stops movement	stops movement
Opening	no effect	no effect	no effect	stops movement
Stopped	completes opening <sup>(2)</sup>	completes closing <sup>(2)</sup>	prevents closing	no effect

**TABLE 11** LOGIC C (DEAD MAN)

LOGIC C	CONTROLS HELD DOWN CONTINUOUSLY		PULSES	
	OPEN A <sup>(4)</sup>	OPEN B <sup>(4-5)</sup>	SAFETY DEVICES	STOP
<b>Closed</b>	opens	no effect	no effect	no effect
<b>Open on pause</b>	no effect	closes	prevents closing	no effect
<b>Closing</b>	no effect		stops movement	stops movement
<b>Opening</b>		no effect	no effect	stops movement
<b>Stopped</b>	completes opening	completes closing	prevents closing	no effect

- (1) **OPEN B** input commands partial opening.
- (2) With pre-flashing selected, movement begins after 5 sec.
- (3) If the pulse is sent during pre-flashing, counting is restarted.
- (4) **OPEN B** input commands closing.
- (5) Push-button must be kept pressed to activate gate movement. When the push-button is released, the gate stops.

**5. FAULT CONDITIONS**

The following conditions cause certain effects to normal operation of automation:

- a-** microprocessor error
  - b-** safety electronic timing tripped (operation is interrupted if continuous work time exceeds 255 sec. ).
  - c-** limit sensors disconnected (or both engaged)
    - Conditions **a** and **b** cause automation to stop and nothing more.
    - Condition **c** causes an alarm situation disabling any activity: Normal operation can be restored only after eliminating the alarm cause and pressing the RESET push-button (or turning off power supply momentarily).
- To have this condition signalled, the warning light must be connected: the alarm is signalled by very rapidly flashing light (0.25 sec).

**6. ROTATION DIRECTION CHECK**

- 1) Release the operator, take it manually to mid-travel and re-lock it.
- 2) Power up the system and then press the RESET push-button.
- 3) Give an Open command to the operator, check if the gate moves in opening direction and then press the RESET push-button to stop the leaf moving.
- 4) If rotation direction is incorrect, change over wiring of cables T1 and T3 of the electric motor.

**7. LIMIT SENSORS CONNECTION CHECK**

Command opening of the gate, and check if, with the leaf open, the FCC LED is lighted and the FCA LED is off. Command the gate to re-close (or wait for pause time to elapse in case of automatic logic) and check if, with the leaf closed, the FCA LED is lighted and the FCC LED is off. If the LEDs are reversed, change over the cables connected to terminals 12 and 13.

**8. ELECTRICAL CONNECTIONS WITH 230V 3ph**

To connect the appliance to a 3-phase 230 V mains, observe the diagram in Fig.8.

**N.B.:** The electric motor of the gearmotor must be 230V 3-phase.

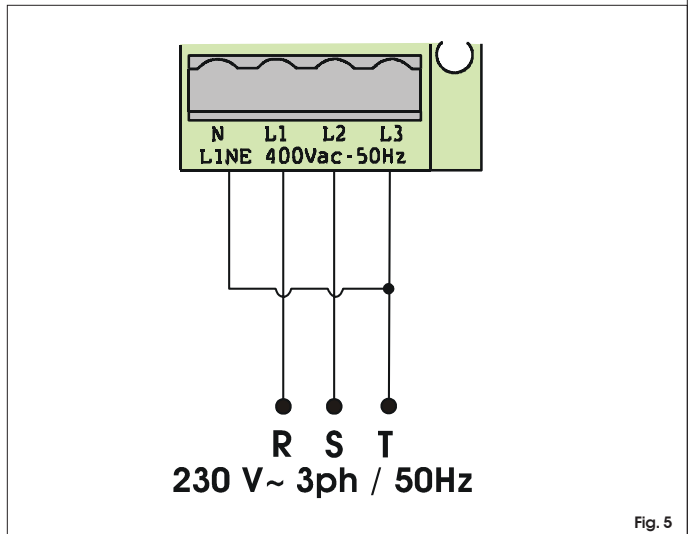

Fig. 5

**9. NOTES**

- 16) Les dispositifs de sécurité (norme EN 12978) permettent de protéger des zones éventuellement dangereuses contre les **Risques mécaniques du mouvement**, comme l'écrasement, l'acheminement, le cisaillement.
- 17) On recommande que toute installation soit dotée au moins d'une signalisation lumineuse, d'un panneau de signalisation fixé, de manière appropriée, sur la structure de la fermeture, ainsi que des dispositifs cités au point "16".
- 18) GENIUS décline toute responsabilité quant à la sécurité et au bon fonctionnement de l'automatisme si les composants utilisés dans l'installation n'appartiennent pas à la production GENIUS.
- 19) Utiliser exclusivement, pour l'entretien, des pièces GENIUS originales.
- 20) Ne jamais modifier les composants faisant partie du système d'automatisme.
- 21) L'installateur doit fournir toutes les informations relatives au fonctionnement manuel du système en cas d'urgence et remettre à l'Usager qui utilise l'installation les "Instructions pour l'Usager" fournies avec le produit.
- 22) Interdire aux enfants ou aux tiers de stationner près du produit durant le fonctionnement.
- 23) Eloigner de la portée des enfants les radiocommandes ou tout autre générateur d'impulsions, pour éviter tout actionnement involontaire de l'automatisme.
- 24) Le transit entre les vantaux ne doit avoir lieu que lorsque le portail est complètement ouvert.
- 25) L'Usager qui utilise l'installation doit éviter toute tentative de réparation ou d'intervention directe et s'adresser uniquement à un personnel qualifié.
- 26) **Tout ce qui n'est pas prévu expressément dans ces instructions est interdit.**

## ADVERTENCIAS PARA EL INSTALADOR

### REGLAS GENERALES PARA LA SEGURIDAD

- 1) **¡ATENCIÓN! Es sumamente importante para la seguridad de las personas seguir atentamente las presentes instrucciones. Una instalación incorrecta o un uso impropio del producto puede causar graves daños a las personas.**
- 2) Lean detenidamente las instrucciones antes de instalar el producto.
- 3) Los materiales del embalaje (plástico, poliestireno, etc.) no deben dejarse al alcance de los niños, ya que constituyen fuentes potenciales de peligro.
- 4) Guarden las instrucciones para futuras consultas.
- 5) Este producto ha sido proyectado y fabricado exclusivamente para la utilización indicada en el presente manual. Cualquier uso diverso del previsto podría perjudicar el funcionamiento del producto y/o representar fuente de peligro.
- 6) GENIUS declina cualquier responsabilidad derivada de un uso impropio o diverso del previsto.
- 7) No instalen el aparato en atmósfera explosiva: la presencia de gas o humos inflamables constituye un grave peligro para la seguridad.
- 8) Los elementos constructivos mecánicos deben estar de acuerdo con lo establecido en las Normas EN 12604 y EN 12605.  
Para los países no pertenecientes a la CEE, además de las referencias normativas nacionales, para obtener un nivel de seguridad adecuado, deben seguirse las Normas arriba indicadas.
- 9) GENIUS no es responsable del incumplimiento de las buenas técnicas de fabricación de los cierres que se han de motorizar, así como de las deformaciones que pudieran intervenir en la utilización.
- 10) La instalación debe ser realizada de conformidad con las Normas EN 12453 y EN 12445. El nivel de seguridad de la automatización debe ser C+D.
- 11) Quitar la alimentación eléctrica y desconectar las baterías antes de efectuar cualquier intervención en la instalación.
- 12) Coloquen en la red de alimentación de la automatización un interruptor omnipolar con distancia de apertura de los contactos igual o superior a 3 mm. Se aconseja usar un magnetotérmico de 6A con interrupción omnipolar.
- 13) Comprueben que la instalación disponga línea arriba de un interruptor diferencial con umbral de 0,03 A.
- 14) Verifiquen que la instalación de tierra esté correctamente realizada y conecten las partes metálicas del cierre.
- 15) La automatización dispone de un dispositivo de seguridad antiaplastamiento constituido por un control de par. No obstante, es necesario comprobar el umbral de intervención según lo previsto en las Normas indicadas en el punto 10.
- 16) Los dispositivos de seguridad (norma EN 12978) permiten proteger posibles áreas de peligro de **Riesgos mecánicos de movimiento**, como por ej. aplastamiento, arrastre, corte.
- 17) Para cada equipo se aconseja usar por lo menos una señalización luminosa así como un cartel de señalización adecuadamente fijado a la estructura del bastidor, además de los dispositivos indicados en el "16".
- 18) GENIUS declina toda responsabilidad relativa a la seguridad y al buen funcionamiento de la automatización si se utilizan componentes de la instalación que no sean de producción GENIUS.
- 19) Para el mantenimiento utilicen exclusivamente piezas originales GENIUS
- 20) No efectúen ninguna modificación en los componentes que forman parte del sistema de automatización.
- 21) El instalador debe proporcionar todas las informaciones relativas al funcionamiento del sistema en caso de emergencia y entregar al usuario del equipo el manual de advertencias que se adjunta al producto.
- 22) No permitan que niños o personas se detengan en proximidad del producto durante su funcionamiento.
- 23) Mantengan lejos del alcance los niños los teletandos o cualquier otro emisor de impulso, para evitar que la automatización pueda ser accionada involuntariamente.

- 24) Sólo puede transitarse entre las hojas si la cancela está completamente abierta.
- 25) El usuario no debe por ningún motivo intentar reparar o modificar el producto, debe siempre dirigirse a personal cualificado.
- 26) **Todo lo que no esté previsto expresamente en las presentes instrucciones debe entenderse como no permitido**

## HINWEISE FÜR DEN INSTALLATIONSTECHNIKER

### ALLGEMEINE SICHERHEITSVORSCHRIFTEN

- 1) **ACHTUNG! Um die Sicherheit von Personen zu gewährleisten, sollte die Anleitung aufmerksam befolgt werden. Eine falsche Installation oder ein fehlerhafter Betrieb des Produktes können zu schwerwiegenden Personenschäden führen.**
- 2) Bevor mit der Installation des Produktes begonnen wird, sollten die Anleitungen aufmerksam gelesen werden.
- 3) Das Verpackungsmaterial (Kunststoff, Styropor, usw.) sollte nicht in Reichweite von Kindern aufbewahrt werden, da es eine potentielle Gefahrenquelle darstellt.
- 4) Die Anleitung sollte aufbewahrt werden, um auch in Zukunft Bezug auf sie nehmen zu können.
- 5) Dieses Produkt wurde ausschließlich für den in diesen Unterlagen angegebenen Gebrauch entwickelt und hergestellt. Jeder andere Gebrauch, der nicht ausdrücklich angegeben ist, könnte die Unversehrtheit des Produktes beeinträchtigen und/oder eine Gefahrenquelle darstellen.
- 6) Die Firma GENIUS lehnt jede Haftung für Schäden, die durch unsachgemäßen oder nicht bestimmungsgemäßen Gebrauch der Automatik verursacht werden, ab.
- 7) Das Gerät sollte nicht in explosionsgefährdeten Umgebungen installiert werden: das Vorhandensein von entflammenden Gasen oder Rauch stellt ein schwerwiegendes Sicherheitsrisiko dar.
- 8) Die mechanischen Bauelemente müssen den Anforderungen der Normen EN 12604 und EN 12605 entsprechen.  
Für Länder, die nicht der Europäischen Union angehören, sind für die Gewährleistung eines entsprechenden Sicherheitsniveaus neben den nationalen gesetzlichen Bezugsvorschriften die oben aufgeführten Normen zu beachten.
- 9) Die Firma GENIUS übernimmt keine Haftung im Falle von nicht fachgerechten Ausführungen bei der Herstellung der anzutreibenden Schließvorrichtungen sowie bei Deformationen, die eventuell beim Betrieb entstehen.
- 10) Die Installation muß unter Beachtung der Normen EN 12453 und EN 12445 erfolgen. Die Sicherheitsstufe der Automatik sollte C+D sein.
- 11) Vor der Ausführung jeglicher Eingriffe auf der Anlage sind die elektrische Versorgung und die Batterie abzunehmen.
- 12) Auf dem Versorgungsnetz der Automatik ist ein omnipolarer Schalter mit Öffnungsabstand der Kontakte von über oder gleich 3 mm einzubauen. Darüber hinaus wird der Einsatz eines Magnetschutzschalters mit 6A mit omnipolarer Abschaltung empfohlen.
- 13) Es sollte überprüft werden, ob vor der Anlage ein Differentialschalter mit einer Auslöseschwelle von 0,03 A zwischengeschaltet ist.
- 14) Es sollte überprüft werden, ob die Erdungsanlage fachgerecht ausgeführt wurde. Die Metallteile der Schließung sollten an diese Anlage angeschlossen werden.
- 15) Die Automation verfügt über eine eingebaute Sicherheitsvorrichtung für den Quetschschutz, die aus einer Drehmomentkontrolle besteht. Es ist in jedem Falle erforderlich, deren Eingriffsschwelle gemäß der Vorgaben der unter Punkt 10 angegebenen Vorschriften zu überprüfen.
- 16) Die Sicherheitsvorrichtungen (Norm EN 12978) ermöglichen den Schutz eventueller Gefahrenbereiche vor **mechanischen Bewegungsrisiken**, wie zum Beispiel Quetschungen, Mitschleifen oder Schnittverletzungen.
- 17) Für jede Anlage wird der Einsatz von mindestens einem Leuchtsignal empfohlen sowie eines Hinweisschildes, das über eine entsprechende Befestigung mit dem Aufbau des Tors verbunden wird. Darüber hinaus sind die unter Punkt "16" erwähnten Vorrichtungen einzusetzen.
- 18) Die Firma GENIUS lehnt jede Haftung hinsichtlich der Sicherheit und des störungsfreien Betriebs der Automatik ab, soweit Komponenten auf der Anlage eingesetzt werden, die nicht im Hause GENIUS hergestellt wurden.
- 19) Bei der Instandhaltung sollten ausschließlich Originalteile der Firma GENIUS verwendet werden.
- 20) Auf den Komponenten, die Teil des Automationssystems sind, sollten keine Veränderungen vorgenommen werden.
- 21) Der Installateur sollte alle Informationen hinsichtlich des manuellen Betriebs des Systems in Notfällen liefern und dem Betreiber der Anlage das Anleitungsbuch, das dem Produkt beigelegt ist, übergeben.
- 22) Weder Kinder noch Erwachsene sollten sich während des Betriebs in der unmittelbaren Nähe der Automation aufhalten.
- 23) Die Funksteuerungen und alle anderen Impulsgeber sollten außerhalb der Reichweite von Kindern aufbewahrt werden, um ein versehentliches Aktivieren der Automation zu vermeiden.
- 24) Der Durchgang oder die Durchfahrt zwischen den Flügeln darf lediglich bei vollständig geöffnetem Tor erfolgen.
- 25) Der Betreiber sollte keinerlei Reparaturen oder direkte Eingriffe auf der Automation ausführen, sondern sich hierfür ausschließlich an qualifiziertes Fachpersonal wenden.
- 26) **Alle Vorgehensweisen, die nicht ausdrücklich in der vorliegenden Anleitung vorgesehen sind, sind nicht zulässig**

Le descrizioni e le illustrazioni del presente manuale non sono impegnative. GENIUS si riserva il diritto, lasciando inalterate le caratteristiche essenziali dell'apparecchiatura, di apportare in qualunque momento e senza impegnarsi ad aggiornare la presente pubblicazione, le modifiche che essa ritiene convenienti per miglioramenti tecnici o per qualsiasi altra esigenza di carattere costruttivo o commerciale.

The descriptions and illustrations contained in the present manual are not binding. GENIUS reserves the right, while leaving the main features of the equipments unaltered, to undertake any modifications to hold necessary for either technical or commercial reasons, at any time and without revising the present publication.

Les descriptions et les illustrations du présent manuel sont fournies à titre indicatif. GENIUS se réserve le droit d'apporter à tout moment les modifications qu'elle jugera utiles sur ce produit tout en conservant les caractéristiques essentielles, sans devoir pour autant mettre à jour cette publication.

Las descripciones y las ilustraciones de este manual no comportan compromiso alguno. GENIUS se reserva el derecho, dejando inmutadas las características esenciales de los aparatos, de aportar, en cualquier momento y sin comprometerse a poner al día la presente publicación, todas las modificaciones que considere oportunas para el perfeccionamiento técnico o para cualquier otro tipo de exigencia de carácter constructivo o comercial.

Die Beschreibungen und Abbildungen in vorliegendem Handbuch sind unverbindlich. GENIUS behält sich das Recht vor, ohne die wesentlichen Eigenschaften dieses Gerätes zu verändern und ohne Verbindlichkeiten in Bezug auf die Neufassung der vorliegenden Anleitungen, technisch bzw. konstruktiv / kommerziell bedingte Verbesserungen vorzunehmen.

Timbro rivenditore: / Distributor's stamp: / Timbre de l'agent: /  
Sello del revendedor: / Fachhändlerstempel:

**GENIUS S.p.A.**  
Via Padre Elzi, 32  
24050 - Grassobbio  
BERGAMO-ITALY  
tel. 0039.035.4242511  
fax. 0039.035.4242600  
info@geniusg.com  
www.geniusg.com

