

General information

- Single source for top service and advanced expertise
- Phone list, Freight charges, Repair charges
- Load diagram, tubes conforming DIN 2248
- Protection classes according to EN 60529

ELEKTROMATEN SI Safedrive®

with integrated safety brake

- For roller shutters, rolling grilles, non-balanced sectional doors, vertically lifted doors, high-speed rolling doors, which require an anti-fallback device

ELEKTROMATEN KE Chain drive

- For roller shutters, rolling grilles, and vertically lifted doors

ELEKTROMATEN SE Sectional door-drive

- For counterbalanced sectional doors

ELEKTROMATEN ST Sliding-door-drive

- For Sliding doors

ELEKTROMATEN Special drives

- ELEKTROMATEN comply to ATEX (SI, KE, SE-ELEKTROMATEN)
- FS-ELEKTROMATEN for fire door-drive
- FT-ELEKTROMATEN for folding doors

Safety brakes

- For doors which requiring an anti-fallback device

Control panels

- For ELEKTROMATEN with
- Mechanical limit NES
 - Digital limit DES

Accessories/ spare parts

- Safety devices
- Accessories
- Spare parts

0

1

2

3

4

5

6

7

8

ELEKTROMATEN KE

Chain-drive

for roller shutters, rolling grilles and vertical lifted doors. Protection of rising doors against falling back requires a safety brake of the appropriate size



KE 9.24 - KE 120.24

Output torque: 90 - 1,200 Nm
Output speed 24 rpm

Data sheet

2.11

Price list

2.19

ELEKTROMATEN KE

Chain-drive

Series SG50
KE 9.24

Series SG85
KE 20.24 - KE 40.24

Series SG115
KE 60.24 - KE 120.24

For driving: Roller shutters and rolling grilles

ELEKTROMATEN KE are special drives for industrial doors. The door shaft is driven by a chain-transmission.

For rising loads a safety brake of the appropriate size must be fitted.

ELEKTROMATEN KE comprises:

Worm gear, interchangeable output-shaft, emergency manual operator, integrated limit switches and electrical motor.

Control panels to suit all requirements can be found in section 7.

Output side:

The interchangeable output-shaft allows easy modification from left- to right-hand use.

Approvals and certificates

ELEKTROMATEN and control panels:
Mark approval certificate according to DIN EN 12453

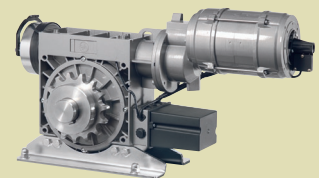
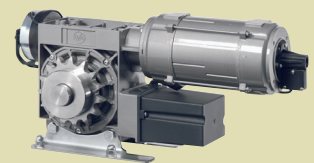
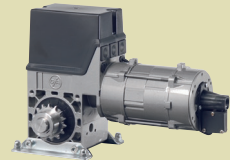

1

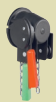

2



3



4



5



6



7

Emergency manual operation

- Hand crank NHK **1**
- Rapid hand chain operator SK for KE 9.24 **2**
- Hand chain operator KNH from KE 20.24 **3**

Limit switches

Mechanical limit NES **4**

- For WS 900, TS 956/961 control panels
- 2 operating, 2 emergency- and 2 auxiliary limit switches

Digital limit DES **5**

- For TS 958/970/981 control panels
- Absolute encoder
- After a power failure, re-adjustment is not required.

Mounting

- Foot angle (standard fitting)
- Bracket (page 2.17)
- Slide rails (page 2.17)

Special versions

- Higher motor duty cycle
- Higher protection class
- Other voltages, frequencies on request
- Explosion-proof according to ATEX (page 5.11)

Control panels

- Simple connection to the limit switch by means of non-interchangeable plug connections allowing simple exchange with other GfA control panels.
- Control voltage: 24V, 50Hz
- Supply voltage: 1x230V/N/PE, 3x230V/PE, 3x400V/N/PE, 3x400V/PE

To be used with mechanical limit switch NES

- Reversing contactor control WS 900 (page 7.11) **6**
- Hold to run control panel TS 956 (page 7.21) **7**
- Automatic control panel TS 961 (page 7.31) **7**

To be used with digital limit switch DES

- Hold to run control panel TS 958 (page 7.25) **7**
- Automatic control panel TS 970 (page 7.41) **7**
- Automatic control panel with traffic management TS 981 (page 7.51) **7**

Details of the above GfA control panels can be found in section 7.

1. Technical data

ELEKTROMATEN Series		KE 9.24 SG50	KE 9.24 WS SG50	KE 20.24 SG85	KE 30.24 SG85
Output torque	Nm	90	90	200	300
Output speed	rpm	24	24	24	24
Output-shaft Ø	mm	25	25	40	40
Permitted OPEN / CLOSE output speed in frequency-inverter operating mode ¹	rpm	42 / 24	--	42 / 42	42 / 42
Motor power	kW	0,37	0,45	0,40	0,85
Supply voltage, frequency	V - Hz	3x230/400-50	1x230-50	3x230/400-50	3x230/400-50
Nominal current ²	A	2,1 / 1,2	3,9	3,1 / 1,8	3,7 / 2,1
Motor duty cycle	ED	S3-60%	S3-20%	S3-60%	S3-60%
Max. cycles per hour ³		12	12	16	14
Supply side wiring / fusing (delayed action)		5x1,5 ² / 10A	3x1,5 ² / 10A	5x1,5 ² / 10A	5x1,5 ² / 10A
Limit switch range ⁴		20 (40)	20 (40)	20 (40, 60, 110)	20 (40, 60, 110)
Max. hand force NHK / SK and / or KNH ⁵	N	70 / 180	70 / 180	150 / 90	190 / 110
ELEKTROMATEN weight	Kg	16	17	23	28
Spare parts: Catalogue page		8.71	8.71	8.72	8.72
Part no. installation drawing (dxf, dwg)		50000577	50000852	50000579	50000579
Part no. ELEKTROMATEN		10002208	10002268	10002232	10002233

ELEKTROMATEN Series		KE 40.24 SG85	KE 60.24 SG115	KE 80.24 SG115	KE 120.24 SG115
Output torque	Nm	400	600	800	1200
Output speed	rpm	24	24	24	24
Output-shaft Ø	mm	40	55	55	55
Permitted OPEN / CLOSE output speed in frequency-inverter operating mode ¹	rpm	42 / 42	42 / 42	42 / 42	42 / 42
Motor power	kW	1,10	1,50	2,00	3,00
Supply voltage, frequency	V - Hz	3x230/400-50	3x230/400-50	3x230/400-50	3x230/400-50
Nominal current ²	A	4,6 / 2,7	6,8 / 3,9	8,1 / 4,7	12,0 / 6,9
Motor duty cycle	ED	S3-60%	S3-60%	S3-60%	S3-60%
Max. cycles per hour ³		12	14	12	10
Supply side wiring / fusing (delayed action)		5x1,5 ² / 10A	5x2,5 ² / 16A	5x2,5 ² / 16A	5x2,5 ² / 16A
Limit switch range ⁴		20 (40, 60, 110)	20 (60, 110)	20 (60, 110)	20 (60, 110)
Max. hand force NHK / KNH ⁵	N	225 / 135	190 / 155	300 / 240	225 / 180
ELEKTROMATEN weight	kg	31	48	52	58
Spare parts: Catalogue page		8.72	8.73	8.74	8.74
Part no. installation drawing (dxf, dwg)		50000579	50000796	50000822	50000797
Part no. ELEKTROMATEN		10002234	10002538	10002539	10002570

The following applies for all ELEKTROMATEN: Protection class IP54, permissible temperature range -5°C to +40°C, operating sound pressure level SPL <70 dB(A)
¹ We recommend to select a special ELEKTROMATEN (enquire) for use with frequency inverter, OPEN drive speed at 87 Hz, read note in 3.7 · ² The operating current in door drives can reach up to 4x the rated current for limited periods, read notes in 3.6 and 3.7 · ³ Read note in 3.2 · ⁴ Maximum possible revolutions of output-shaft · ⁵ Read note in 3.4

2. Selection chart

ELEKTROMATEN	Tube DIN 2448	Transmission 1:2		Transmission 1:3		Transmission 1:3,8		Transmission 1:4,5	
	[mm]	F [N]	v _a [cm/s]	F [N]	v _a [cm/s]	F [N]	v _a [cm/s]	F [N]	v _a [cm/s]
KE 9.24 / KE 9.24 WS	101,6 x 3,6	2368	7,6	3553	5,1	4500	4,0	5329	3,4
	108,0 x 3,6	2250	8,0	3375	5,4	4275	4,2	5063	3,6
	133,0 x 4,0	1882	9,6	2824	6,4	3576	5,1	4235	4,3
	159,0 x 4,5	1609	11,2	2413	7,5	3057	5,9	3620	5,0
KE 20.24	133,0 x 4,0	4183	9,6	6275	6,4	7948	5,1	9412	4,3
	159,0 x 4,5	3575	11,2	5363	7,5	6793	5,9	8045	5,0
	177,8 x 5,0	3236	12,4	4853	8,3	6148	6,5	7280	5,5
	193,7 x 5,4	2995	13,4	4492	9,0	5690	7,1	6738	6,0
KE 30.24	219,1 x 5,9	2677	15,0	4015	10,0	5086	7,9	6023	6,7
	133,0 x 4,0	6275	9,6	9412	6,4	11922	5,1	14118	4,3
	159,0 x 4,5	5363	11,2	8045	7,5	10190	5,9	12067	5,0
	177,8 x 5,0	4853	12,4	7280	8,3	9221	6,5	10920	5,5
KE 40.24	193,7 x 5,4	4492	13,4	6738	9,0	8535	7,1	10108	6,0
	219,1 x 5,9	4015	15,0	6023	10,0	7629	7,9	9034	6,7
	159,0 x 4,5	7151	11,2	10726	7,5	13587	5,9	16089	5,0
	177,8 x 5,0	6471	12,4	9707	8,3	12295	6,5	14560	5,5
KE 60.24	193,7 x 5,4	5990	13,4	8985	9,0	11380	7,1	13477	6,0
	219,1 x 5,9	5353	15,0	8030	10,0	10171	7,9	12045	6,7
	244,5 x 6,3	4839	16,6	7259	11,1	9195	8,7	10888	7,4
	273,0 x 6,3	4369	18,4	6553	12,3	8300	9,7	9829	8,2
KE 80.24	298,5 x 7,1	4019	20,0	6028	13,3	7636	10,5	9042	8,9
	323,9 x 7,1	3722	21,6	5583	14,4	7072	11,4	8375	9,6
	177,8 x 5,0	9707	12,4	14560	8,3	18443	6,5	21840	5,5
	193,7 x 5,4	8985	13,4	13477	9,0	17071	7,1	20215	6,0
KE 100.24	219,1 x 5,9	8030	15,0	12045	10,0	15257	7,9	18068	6,7
	244,5 x 6,3	7259	16,6	10888	11,1	13792	8,7	16333	7,4
	273,0 x 6,3	6553	18,4	9829	12,3	12451	9,7	14744	8,2
	298,5 x 7,1	6028	20,0	9042	13,3	11454	10,5	13564	8,9
KE 120.24	323,9 x 7,1	5583	21,6	8375	14,4	10608	11,4	12562	9,6
	177,8 x 5,0	12942	12,4	19414	8,3	24590	6,5	29120	5,5
	193,7 x 5,4	11979	13,4	17969	9,0	22761	7,1	26954	6,0
	219,1 x 5,9	10707	15,0	16060	10,0	20343	7,9	24090	6,7
KE 150.24	244,5 x 6,3	9679	16,6	14518	11,1	18389	8,7	21777	7,4
	273,0 x 6,3	8737	18,4	13106	12,3	16601	9,7	19659	8,2
	298,5 x 7,1	8038	20,0	12057	13,3	15272	10,5	18085	8,9
	323,9 x 7,1	7444	21,6	11166	14,4	14144	11,4	16749	9,6
KE 180.24	177,8 x 5,0	19414	12,4	29120	8,3	36886	6,5	43680	5,5
	193,7 x 5,4	17969	13,4	26954	9,0	34141	7,1	40431	6,0
	219,1 x 5,9	16060	15,0	24090	10,0	30514	7,9	36136	6,7
	244,5 x 6,3	14518	16,6	21777	11,1	27584	8,7	32665	7,4
KE 200.24	273,0 x 6,3	13106	18,4	19659	12,3	24901	9,7	29488	8,2
	298,5 x 7,1	12057	20,0	18085	13,3	22907	10,5	27127	8,9
	323,9 x 7,1	11166	21,6	16749	14,4	21215	11,4	25124	9,6

■ F = Lift [N]
■ v_a = initial speed [cm/s]

■ Includes 20% friction for single-wall profiles
(profile thickness 20mm)
■ Read note in 3.2

3. Notes

3.1 European directive

In accordance with the product standard DIN EN 13241-1 Doors- and DIN EN 12453 Safety in use of power operated doors-Requirements.

3.2 Selection chart

Reduce weight of the door if the stated number of cycles per hour is exceeded (item 1 of technical data) – e.g. high frequently used doors (enquire).

The selection chart includes 20% friction for roller shutters with single-wall profiles (profile thickness 20mm).

Reduce the weight by a further 20% for vertical lifted doors and insulated shutters with double walled, thick and/or deep sections. Do not calculate using the tube diameter. The highest torque will occur normally after 1-2 turns of the barrel from close.

3.3 Gear self-braking / electric brake / brake release

ELEKTROMATEN without an electro magnetic brake have a self-sustaining worm gear and stop automatically.

On ELEKTROMATEN with electric brake, stopping is achieved by the external brake. Brake inspection must always be carried out by trained service engineers. Ensure that the brake is not released.

3.4 Manual operation

In accordance with EN 12453 and 12604 hand force up to 390N is permissible. For large, heavy doors manual operation is only used for closing the door.

In the case of ELEKTROMATEN units with electric brake, emergency manual operation is carried out against the engaged brake.

3.5 Safety brake

For rising loads a safety brake of the appropriate size must be fitted. The admissible drive speeds for the safety brake may not be exceeded. The locking torque moment must not exceed

the admissible loads on mechanical components such as e.g. fixings, shafts, keys etc.

3.6 Motor overload protection

Motor overload protection must be able to withstand 4x the nominal motor current because the starting current of the drive unit can reach these levels for short periods.

3.7 Use with frequency inverter

A higher than recommended drive speed puts extra load onto the gear. This extra load must be taken into account when sizing a drive by reducing the available output torque.

Increasing the drive speed by 10% reduces the admissible drive torque by 5%. In the case of higher drive speeds reduce the drive torque accordingly (enquire if necessary).

The admissible drive speeds may not be exceeded (item 1, technical data). The operating forces must comply with DIN EN 12453.

If selecting a frequency inverter, note that the starting current of the drive unit can reach 4x of the nominal motor current.

When using a frequency inverter we recommend ELEKTROMATEN in special version (enquire).

3.8 Chain drive

It is not allowed to exceed the admissible loads on chains, shafts, keys and bearings. Observe the direction of the power input.

We recommend the use of drive sprockets with at least 15 teeth. The drive sprocket must not protrude beyond the end of the output-shaft.

The chain drive transmission is to be fitted with tensioning devices designed to prevent the chain riding up or disengaging.

4.1 Dimensions • KE 9.24/KE 9.24 WS

Series SG50

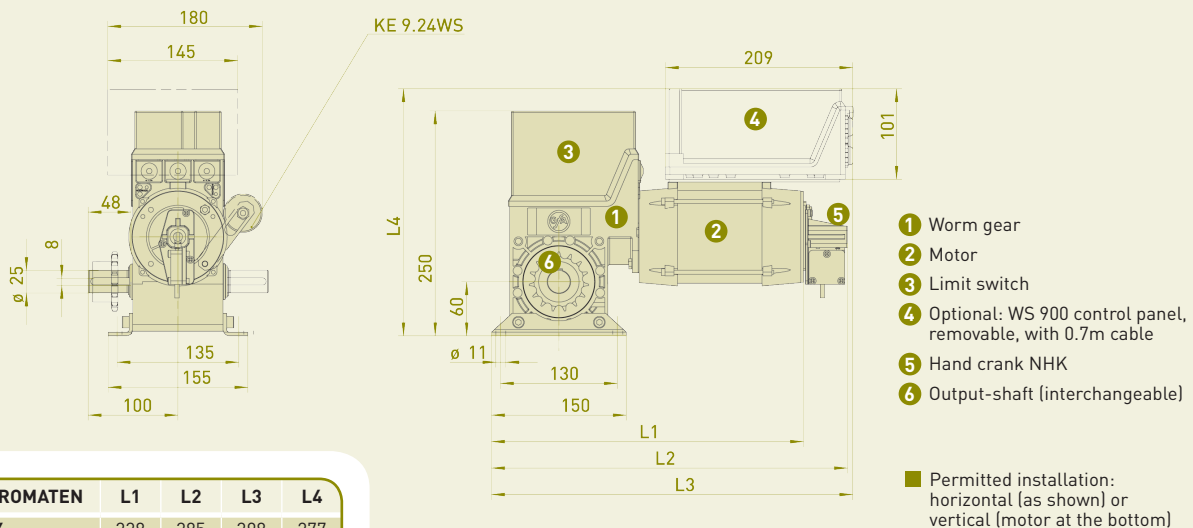

ELEKTROMATEN	L1	L2	L3	L4
KE 9.24	338	385	398	277
KE 9.24 WS	349	396	396	285

4.2 Dimensions • KE 20.24 / KE 30.24 / KE 40.24

Series SG85

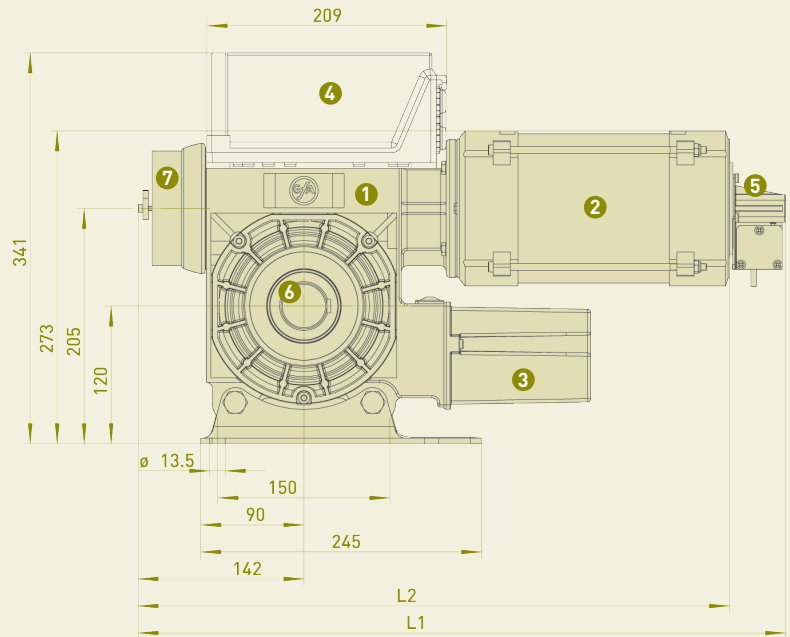
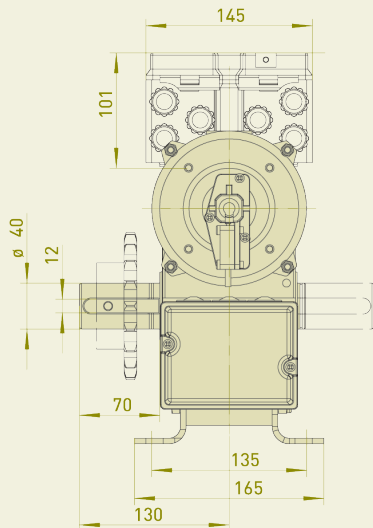

- ① Worm gear
- ② Motor
- ③ Limit switch
- ④ Optional: WS 900 control panel, removable, with 0.7m cable
- ⑤ Hand crank NHK
- ⑥ Output-shaft (interchangeable)
- ⑦ Electric brake

■ Permitted installation:
horizontal (as shown) or
vertical (motor at the bottom)

ELEKTROMATEN	L1	L2
KE 20.24	487	440
KE 30.24	534	487
KE 40.24	566	519

4.3 Dimensions • KE 60.24 / KE 80.24

Series SG115

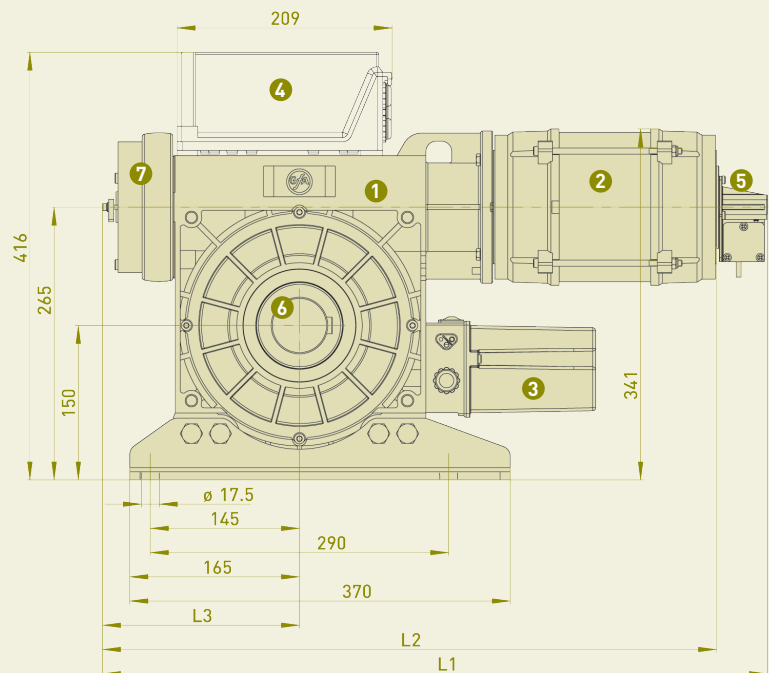
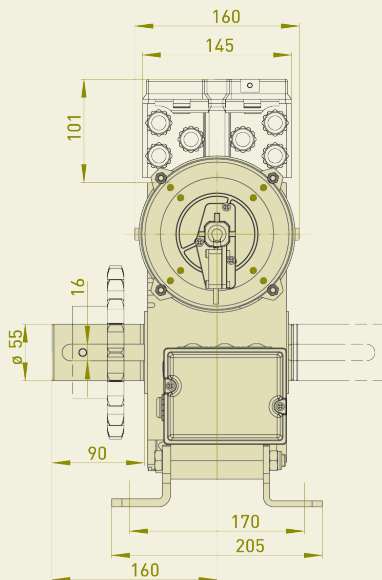

- ① Worm gear
- ② Motor
- ③ Limit switch
- ④ Optional: WS 900 control panel, removable, with 0.7m cable
- ⑤ Hand crank NHK
- ⑥ Output-shaft (interchangeable)
- ⑦ Electric brake

■ Permitted installation:
horizontal (as shown) or
vertical (motor at the bottom)

ELEKTROMATEN	L1	L2	L3
KE 60.24	607	560	179
KE 80.24	645	598	192

4.3 Dimensions • KE 120.24

Series SG115 with intermediate gear

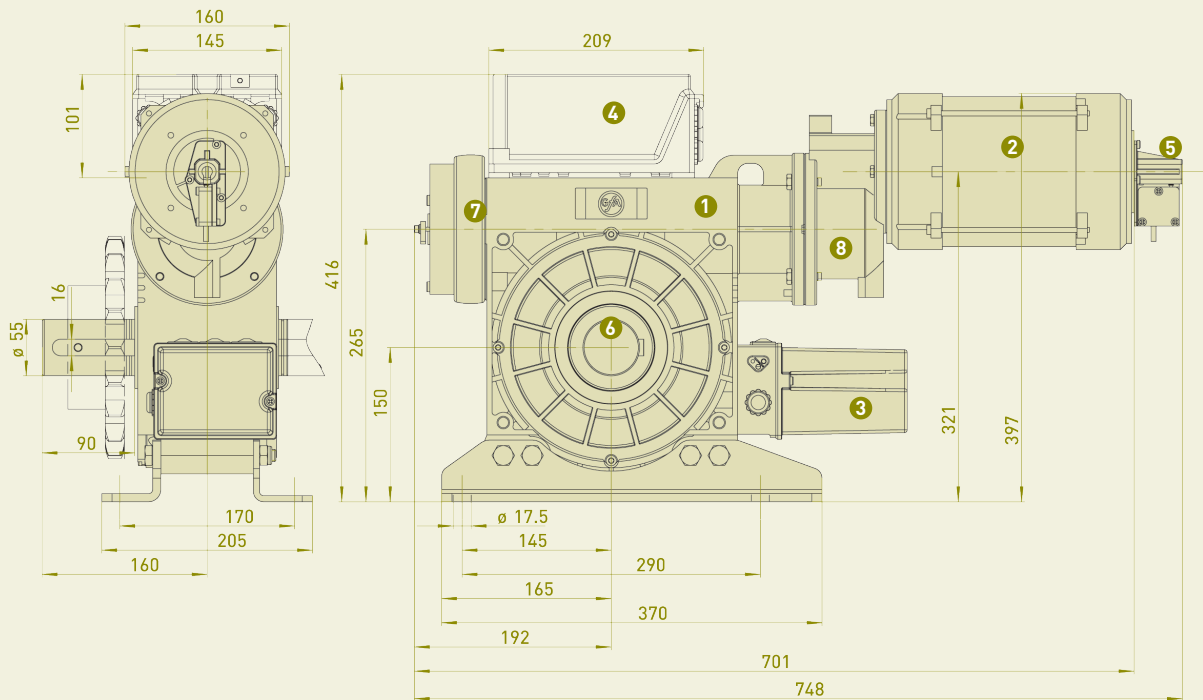

- 1 Worm gear
- 2 Motor
- 3 Limit switch
- 4 Optional: WS 900 control panel, removable, with 0.7m cable

- 5 Hand crank NHK
- 6 Output-shaft (interchangeable)
- 7 Electric brake
- 8 Intermediate gear

■ Permitted installation: horizontal (as shown) or vertical (motor at the bottom)

5. Emergency manual operation for horizontal or vertical installation

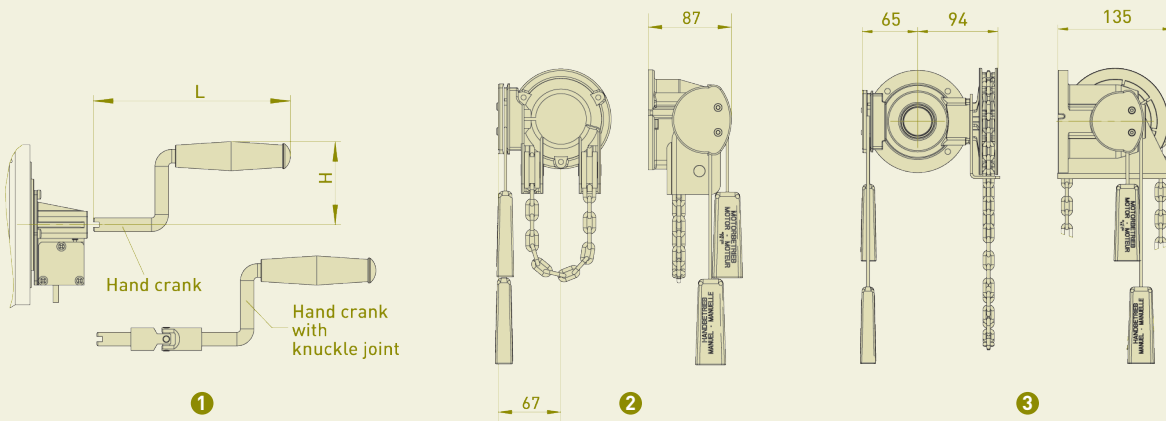

- 1 Manual hand crank operation NHK / NHKK
- 2 Rapid hand chain operator SK for KE 9.24
- 3 Hand chain operator KNH from KE 20.24

■ Manual forces, see item 1 of technical data
 ■ Read note in 3.4

Series	Emergency manual operation NHK / NHKK	L	H	Part no.
SG50	Hand crank	255	92	30002591
	Hand crank with knuckle joint	420	112	30002715
SG85	Hand crank	205	142	30002749
	Hand crank with knuckle joint	420	152	30002750
SG115	Hand crank	265	192	30003112

6.1 Bracket

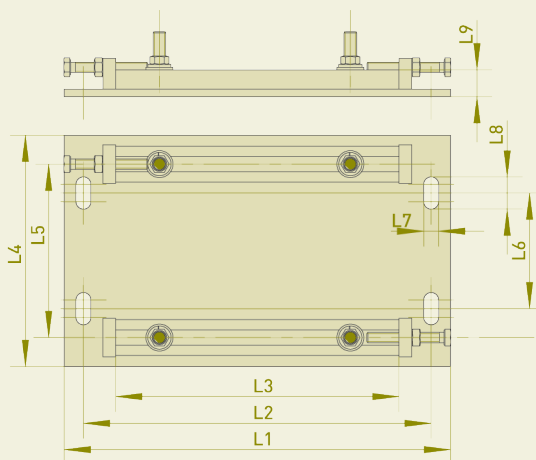

Series	Part no.	L1	L2	L3	L4	L5	L6	L7	L8	L9
SG50	30000567	300	270	220	180	135	90	11,5	25	21
	30002872	380	350	300	180	135	90	11,5	25	23
SG115	30003070	520	485	425	220	170	100	17,5	30	28

6.2 Slide rails (2 pieces)

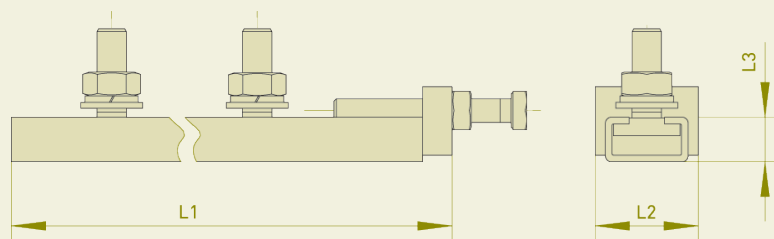

Series	Part no.	L1	L2	L3	Fixing screws
SG50	30001048	250	28	15	M10 x 30
SG85	30000152	360	38	17	M12 x 40
SG115	30003069	420	45	22	M16 x 40

6.3 Sprockets

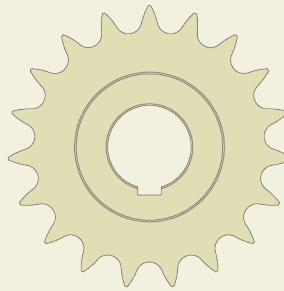
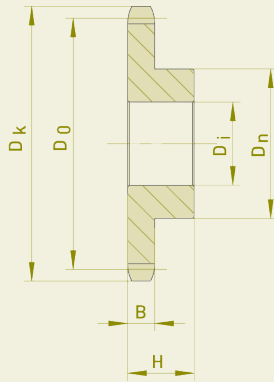

■ Additional sprockets, as in page 8.37

ELEKTROMATEN	DIN designation	Teeth	Part no.	D_k	D_0	D_n	D_i	B	H
KE 9.24	Pitch 08-B1 1/2" x 5/16"	15	30000237	66	61,1	45	25	7,2	20
		19	30000238	82	77,2	60	25	7,2	25
KE 20.24 / KE 30.24	Pitch 12-B1 3/4" x 7/16"	15	30000219	99,3	91,6	70	40	11,1	30
		19	30000220	125	115,7	75	40	11,1	35
KE 30.24 / KE 40.24	Pitch 16-B1 1" x 17,02mm	15	30000171	132,2	122,2	90	40	16,2	40
		19	30000321	165	154,3	90	40	16,2	50
KE 60.24	Pitch 16-B1 1" x 17,02mm	15	30000173	132,2	122,2	90	55	16,2	40
		19	30000688	165	154,3	90	55	16,2	50
KE 80.24 / KE 120.24	Pitch 20-B1 1 1/4" x 3/4"	15	30000920	164,6	152,7	110	55	18,6	55
		19	30003163	205,5	192,9	120	55	18,6	55

6.4 Roller chain

■ For chain and sprockets, the maximum permitted torque M_{ab} on ELEKTROMATEN is as shown in the table (safety factor 6x the breaking strain)

Roller Chain DIN designation	Ultimate load of chain DIN 8187 [N]	Number of teeth's	M_{ab} [Nm]	Part no.
Pitch 08-B1 1/2" x 5/16"	18.000	15	90	1,5m 40005050
		19	115	/ m 40000612
Pitch 12-B1 3/4" x 7/16"	29.000	15	220	2,0m 40003030
		19	280	/ m 40000614
Pitch 16-B1 1" x 17,02mm	60.000	15	610	2,5m 40005049
		19	770	/ m 40000616
Pitch 20-B1 1 1/4" x 3/4"	95.000	15	1200	3,0m 40014878
		19	1520	/ m 40001110

Price list valid from 01.2007 for
ELEKTROMATEN KE
 Chain-drive

Versions according to page 2.11 - 2.18
 All prices in € net/unit

Series SG50
KE 9.24 / KE 9.24 WS

Series SG85
KE 20.24 / KE 30.24 / KE 40.24

Series SG115
KE 60.24 / KE 80.24 / KE 120.24

1. KE ELEKTROMATEN Chain-drive

ELEKTROMATEN	Series	Output torque Nm	Output speed rpm	Output-shaft Ø mm	Spare-part sheet	Part no.	Standard price
Single-phase							
KE 9.24 WS	SG50	90	24	25	8.71	10002268	
Three-phase							
KE 9.24	SG50	90	24	25	8.71	10002208	
KE 20.24	SG85	200	24	40	8.72	10002232	
KE 30.24	SG85	300	24	40	8.72	10002233	
KE 40.24	SG85	400	24	40	8.72	10002234	
KE 60.24	SG115	600	24	55	8.73	10002538	
KE 80.24	SG115	800	24	55	8.74	10002539	
KE 120.24	SG115	1.200	24	55	8.74	10002570	

2. Mounting

Version	Description	Series	Part no.	Extra cost
FW	Foot angle	SG50 SG85 SG115		
K0	Bracket (description: page 2.17, section 6.1)	SG50 SG85 SG115	30000567 30002872 30003070	
SP	Slide rails (description: page 2.17, section 6.2)	SG50 SG85 SG115	30001048 30000152 30003069	

3. Control panel/terminal box with plug connection to ELEKTROMATEN

Version	Description	For limit switch	Part no.	Extra cost
WS 900	Reversing contactor 2 reversing contactor-24V Page 7.11 3 reversing contactor-24V Page 7.11	NES	20090000.10003 20090000.10004	
KK 003	Terminal box	NES	20001848.10001	
TS 956	Hold to run control panel	Page 7.21 NES		
TS 961	Automatic control panel	Page 7.31 NES		
TS 958	Hold to run control panel	Page 7.25 DES		
TS 970	Automatic control panel	Page 7.41 DES		
TS 981	Control panel with traffic management	Page 7.51 DES		

4. Emergency manual operation

Version	Description	Part no.	Extra cost
NHK	Hand crank		
NHKK	Hand crank with knuckle joint (series SG50 / SG85 only)		
SK	Rapid hand chain operator (4m hand chain, 0,5m engaging and disengaging cord) for KE 9.24		
KNH	Hand chain operator (4m [7m at SG115F] hand chain, 0,5m engaging and disengaging cord) from KE 20.24		
Optional accessories SK / KNH	Hand chain with chain link	2m	30004555.00002
		4m	30004555.00004
		6m	30004555.00006
		8m	30004555.00008
	Hand chain (drum with 50m)		40014220
	Chain link (10 pc.)		30004631
	Extension cord	2 x 4 m	30003965
	2 x 10 m	30004242	

5. Limit switches

Version	Description	Extra cost
NES	Mechanical limit switch (2 operating, 2 emergency and 2 additional) 7. Auxiliary limit switch	
DES	Digital limit switch	
Limit switch range	20 revolutions of output-shaft 40 revolutions of output-shaft (series SG50 / SG85) 60, 110 revolutions of output-shaft (series SG85 / SG115)	

6. Electrical accessories

	Description	Part no.	€ net / unit
6.1	Push button No. 31 aP OPEN-STOP-CLOSE Plastic housing	40015034	
6.2	Key switch No. 420 aP OPEN-CLOSE Metal housing No. 430 aP OPEN-STOP-CLOSE Metal housing No. 421 uP OPEN-CLOSE Metal housing	40000308	
		40000310	
		40000309	
	Further control devices and key switches from page 8.21 onwards		
6.3	Main switch In housing, IP65	40000526	
6.4	Radio control 434 MHz, dip-switch coding from page 8.23 onwards		
6.5	Safety edge system from page 8.01 onwards		

7. Mechanical accessories

	Description	Part no.	€ net / unit
7.1	Safety brake FG 40-30 (Description: page 6.11) FG 80-40 (Description: page 6.11) FG 120-50 (Description: page 6.11) Gr. 4 (Description: page 6.21)	10002270	
		10002271	
		10002272	
		10000285	
7.2	Sprockets SG50 08B-1 (1/2"x5/16") Ø25 mm Z=15 Z=19 SG85 12B-1 (3/4"x7/16") Ø40 mm Z=15 Z=19 SG85 16B-1 (1"x17,02mm) Ø40 mm Z=15 Z=19 SG115 16B-1 (1"x17,02mm) Ø55 mm Z=15 Z=19 SG115 20B-1 (1 1/4"x3/4") Ø55 mm Z=15 Z=19	30000237	
		30000238	
		30000219	
		30000220	
		30000171	
		30000321	
		30000173	
		30000688	
7.3	Chain / chain link 08B-1 (1/2"x5/16") 1,5m / m Chain link 12B-1 (3/4"x7/16") 2,0m / m Chain link 16B-1 (1"x17,02mm) 2,5m / m Chain link 20B-1 (1 1/4"x3/4") 3,0m / m Chain link	40005050	
		40000612	
		40000613	
		40003030	
		40000614	
		40005049	
		40000616	
		40000617	
7.4	Pedestal bearing Ø30 mm Ø40 mm Ø50 mm Ø60 mm Ø70 mm Ø80 mm	40000436	
		40000438	
		40000440	
		40000441	
		40000442	
		40000443	
		40000443	
7.5	Shafts S355J2G3C+C (EN 10277-2) Type A (no key, bearing side or for Plate wheels) Type B (with key, for safety brake or for sprockets)	Ø30 mm 40012328	
		Ø40 mm 40012329	
		Ø50 mm 40012330	
		Ø60 mm 40012331	
		Ø70 mm 40012332	
		Ø80 mm 40012664	
		Ø30 mm 30003002	
		Ø40 mm 30003003	
		Ø50 mm 30003004	
		Ø60 mm 30003005	
		Ø70 mm 30003006	
		Ø80 mm 30003184	
		7.6	Disc for tubes 133 x 4,0 mm Ø124 mm 159 x 4,5 mm Ø149 mm 177,8x 5,0 mm Ø166 mm 193,7x 5,4 mm Ø182 mm 219,1x 5,9 mm Ø206 mm 244,5x 6,3 mm Ø206 mm 273,0x 6,3 mm Ø206 mm 298,5x 7,1 mm Ø283 mm 323,9x 7,1 mm Ø308 mm

Additional shafts, discs, bearings, as in page 8.31