



## Mechanical operating instructions

Safedrive - ELEKTROMATEN® SI / SIK



consisting of:

**M : Mechanical operating instructions**

**E : Electrical operating instructions (separately enclosed)**

<b>List of Contents M</b>	<b>Page</b>
GENERAL DIRECTIONS .....	M 3
SAFETY BRAKE WITHIN THE GEARBOX .....	M 3
SAFETY DIRECTIONS .....	M 4
TECHNICAL DATA SI 8.20 / SI 14.15 / SI 14.20 .....	M 6
DIMENSIONS SI 8.20 / SI 14.15 / SI 14.20 .....	M 7
TECHNICAL DATA SIK 20.12 WS / SIK 15.12 / SIK 23.12 .....	M 8
DIMENSIONS SIK 20.12 WS / SIK 15.12 / SIK 23.12 .....	M 9
TECHNICAL DATA SI 17.15 / SI 17.24 .....	M 10
DIMENSIONS SI 17.15 / SI 17.24 .....	M 11
TECHNICAL DATA SI 25.10 / SI 25.15 / SI 25.15 WS / SI 40.10 / SI 40.15 / SI 55.10 / SI 55.15 .....	M 12
DIMENSIONS SI 25.10 / SI 25.15 / SI 25.15 WS / SI 40.10 / SI 40.15 / SI 55.10 / SI 55.15 .....	M 13
TECHNICAL DATA SI 25.24 / SI 25.35 / SI 35.30 / SI 40.24 .....	M 14
DIMENSIONS SI 25.24 / SI 25.35 / SI 35.30 / SI 40.24 .....	M 15
TECHNICAL DATA SI 75.10 / SI 75.15 / SI 100.10 / SI 100.24 / SI 140.7 / SI 60.24 / SI 75.24 .....	M 16
DIMENSIONS SI 75.10 / SI 75.15 / SI 100.10 / SI 100.24 / SI 140.7 / SI 60.24 / SI 75.24 .....	M 17
INSTALLATION INSTRUCTIONS .....	M 18
EMERGENCY MANUAL OPERATION .....	M 19
VOLTAGE CHANGEOVER OF MOTORS .....	M 21
LIMIT SWITCH ADJUSTMENT "The Safedrive compact" .....	M 22
LIMIT SWITCH ADJUSTMENT "The Safedrive" .....	M 23
DIGITAL LIMIT SWITCH (type DES) .....	M 24
ANNUAL INSPECTION .....	M 25
TRANSPORT / STORAGE / DISPOSAL .....	M 26
DECLARATION OF INCORPORATION .....	M 27

For driving all rolling grilles, roller shutters and other horizontal or vertical movements.  
All other applications of the ELEKTROMATEN® need to be approved by the manufacturer.

Where changes are made to the ELEKTROMATEN® (e.g. re-wiring), the manufacturer's declaration of incorporation cease to apply.

## SAFETY BRAKE WITHIN THE GEARBOX

---

The built in safety brake has following advantages:

- safety against breakage of the worm and the worm wheel
- speed independent
- direction independent
- may be mounted in any attitude
- maintenance free
- self - controlling
- excellent damping characteristics in operation

## Basic Directions

This drive has been built and tested in accordance with **DIN EN 12453 Industrial, commercial and garage doors and gates - Safety in use of power operated doors - Requirements** and **DIN EN 12604 Industrial, commercial and garage doors and gates - Mechanical aspects - Requirements** and left the factory in perfect condition from the point of view of safety. To maintain this condition and to ensure safe operation, the user must observe all the directions and warnings contained in these operating instructions.

In principle, only trained electrical craftsmen should work on electrical equipment. They must assess the work which has been assigned to them, identify potential danger sources and take suitable safety precautions.

Reconstruction of or changes to ELEKTROMATEN® are only permissible with the approval of the manufacturer. Original replacement parts and accessories authorised by the manufacturer guarantee safety. Liability ceases to apply if other parts are used.

The operational safety of an ELEKTROMATEN® is only guaranteed if it is used in accordance with the regulations. The limiting values stated in the technical data should not be exceeded under any circumstances (see corresponding sections of the operating instructions).

## Safety Regulations

During the installation, initial operation, maintenance and testing of the ELEKTROMATEN®, it is necessary to observe the safety and accident-prevention regulations valid for the specific application.

In particular, you should observe the following regulations (this list is not exhaustive):

European normative

- DIN EN 12453  
Safety in use of power operated doors - Requirements
- DIN EN 12604  
Industrial, commercial and garage doors and gates - Mechanical aspects - Requirements

Please check normative's bellow.

VDE-regulations

- VDE 0100  
Regulations regarding the construction of power installations with a nominal voltage of up to 1000 V
- VDE 0105  
Operation of power installations
- DIN EN 60204-1 / VDE 0113-1  
Safety of machinery - Electrical equipment of machines - Part 1:  
General requirements
- DIN EN 60335-1 / VDE 0700-1  
Safety of household and similar electrical appliances - Part 1:  
General requirements



Regulations

- Please ensure that the local regulations relating to the Safety of Operations of Doors are followed

## Explanation of warnings

These operating instructions contain directions which are important for using the ELEKTROMATEN® appropriately and safely.

The individual directions have the following meaning:



### **DANGER**

This indicates danger to the life and health of the user if the appropriate precautions are not taken.



### **CAUTION**

This warns that the ELEKTROMATEN® or other materials may be damaged if the appropriate precautions are not taken.

## General warnings and safety precautions

The following warnings are to be understood as a general guideline for working with the ELEKTROMATEN® in conjunction with other devices. These directions must be observed strictly during installation and operation.



- Please observe the safety and accident prevention regulations valid for the specific application. The installation of the ELEKTROMATEN®, the opening of covers or lids and electrical connection must be carried out when the supply is switched off.
- The ELEKTROMATEN® must be installed with the authorised coverings and protective devices. Care should be taken that any seals are fitted correctly and screw couplings are tightened correctly.
- In the case of ELEKTROMATEN® with a permanent mains connection, an all-pole main switch with appropriate back-up fuse must be provided.
- Check live cables and conductors regularly for insulation faults or breakages. When a fault is detected in the cabling, the defective cabling should be replaced after immediately switching off the mains supply.
- Before starting operation, check whether the permissible mains voltage range of the devices corresponds to the local mains voltage.
- Emergency stop devices in accordance with VDE 0113 should remain operational in all operating modes of the control. Releasing the emergency stop device should not cause any uncontrolled or undefined restart.

Size		SI 8.20	SI 14.15	SI 14.20
output torque	Nm	80	140	140
Locking torque	Nm	310	310	310
output revolutions	min <sup>-1</sup>	20	15	20
motor performance	kW	0,30	0,35	0,45
operational voltage	V	3 x 230/400	3 x 230/400	3 x 230/400
frequency	Hz	50	50	50
control voltage	V	24	24	24
nominal motor current	A	2,6 / 1,5	3,3 / 1,9	3,1 / 1,8
motor duty cycle	ED	S3 - 60%	S3-60%	S3-60%
power supply / fusing on attachment side		5x1,5 <sup>2</sup> / 10A delay	5x1,5 <sup>2</sup> / 10A delay	5x1,5 <sup>2</sup> / 10A delay
limit switch range, max. revolutions of the hollow shaft		20 (14*)	20 (14*)	20 (14*)
permissible temperature range (in the case of deviation, please check)		-5°C / +40°C	-5°C / +40°C	-5°C / +40°C
permanent sound emission	dB(A)	< 70	< 70	< 70
class of protection	IP	54	54	54
ELEKTROMATEN® weight	kg	15,5	17	16

\*Limit switch range for hollowshaft diameter  $\varnothing$  30mm

In the case of structurally similar ELEKTROMATEN® or special sizes, deviations are possible, in particular in the output torque, output revolutions and the motor data. In each case, the details on the nameplate apply.

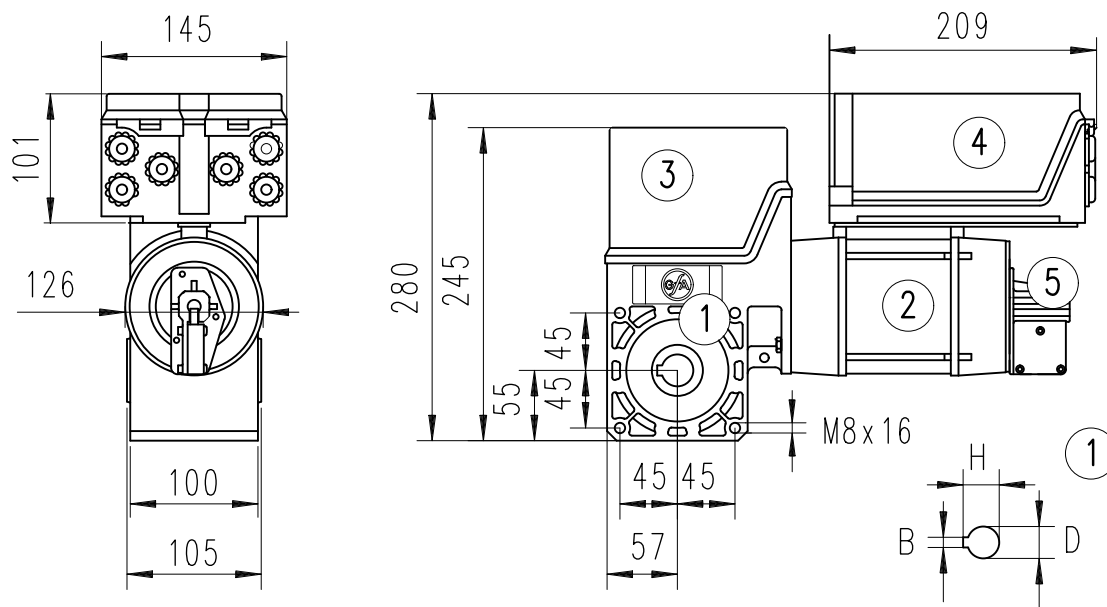

**Model NHK**  
Manual crank

- ① Hollow shaft / worm gear within safety brake
- ② Electric motor
- ③ Limit switch
- ④ Removable reversing contactor with 0,7m cable
- ⑤ Emergency manual operation

Hollow shaft diameter D [mm]	B [mm]	H [mm]
25	8	28,3
25,4	6,35	28,4
30	8,0	33,3

**Max. handforce ( N )**

Model	NHK	KNH
<b>SI 8.20</b>	80	210
<b>SI 14.15</b>	140	110
<b>SI 14.20</b>	140	110

- Subject to dimensional and structural changes  
 - deviations in the overall length and the motor diameter are possible in special sizes

Size		SIK 20.12 WS Single phase	SIK 15.12	SIK 23.12
output torque	Nm	200	150	230
Locking torque	Nm	510	510	510
output revolutions	min <sup>-1</sup>	12	12	12
motor performance	kW	0,40	0,40	0,40
operational voltage	V	1 x 230	3 x 230/400	3 x 230/400
frequency	Hz	50	50	50
control voltage	V	24	24	24
nominal motor current	A	5,4	1,6 / 0,9	2,3 / 1,6
motor duty cycle	ED	S2 - 5 min	S3-60%	S3-60%
power supply / fusing on attachment side		3x1,5 <sup>2</sup> / 10A delay	5x1,5 <sup>2</sup> / 10A delay	5x1,5 <sup>2</sup> / 10A delay
limit switch range, max. revolutions of the hollow shaft		20	20	20
permissible temperature range (in the case of deviation, please check)		-5°C / +40°C	-5°C / +40°C	-5°C / +40°C
permanent sound emission	dB(A)	< 70	< 70	< 70
class of protection	IP	54	54	54
ELEKTROMATEN® weight	kg	16	16	16

In the case of structurally similar ELEKTROMATEN® or special sizes, deviations are possible, in particular in the output torque, output revolutions and the motor data. In each case, the details on the nameplate apply.

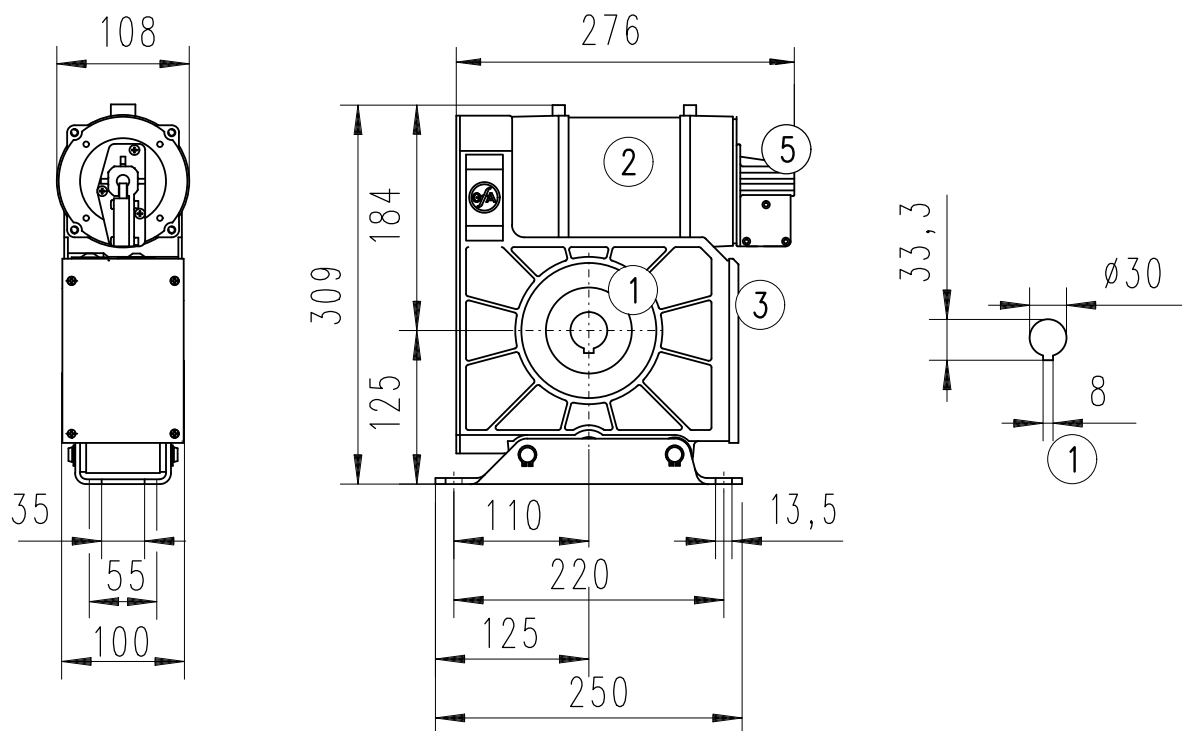

## Model NHK Manual crank

- ① Hollow shaft / worm gear within safety brake
- ② Electric motor
- ③ Limit switch
- ④ Removable reversing contactor with 0.7m cable
- ⑤ Emergency manual operation

### Max. handforce ( N )

Model	NHK	S2K
<b>SIK 20.12 WS</b>	75	200
<b>SIK 15.12</b>	60	150
<b>SIK 23.12</b>	85	230

- Subject to dimensional and structural changes
- deviations in the overall length and the motor diameter are possible in special sizes

Size		SI 17.15	SI 17.24
output torque	Nm	170	170
Locking torque	Nm	510	510
output revolutions	min <sup>-1</sup>	15	24
motor performance	kW	0,40	0,40
operational voltage	V	3 x 230/400	3 x 230/400
frequency	Hz	50	50
control voltage	V	24	24
nominal motor current *	A	4,3 / 2,5	3,3 / 1,9
motor duty cycle	ED	S3-60%	S3-60%
power supply / fusing on attachment side		5x1,5 <sup>2</sup> / 10A delay	5x1,5 <sup>2</sup> / 10A delay
limit switch range, max. revolutions of the hollow shaft		20	20
permissible temperature range (in the case of deviation, please check)		-5°C / +40°C	-5°C / +40°C
permanent sound emission	dB(A)	< 70	< 70
class of protection	IP	54	54
ELEKTROMATEN® weight	kg	15,5	16

\*Important note: The drive unit start current will be higher 4 times than the nominal current!

In the case of structurally similar ELEKTROMATEN® or special sizes, deviations are possible, in particular in the output torque, output revolutions and the motor data. In each case, the details on the nameplate apply.

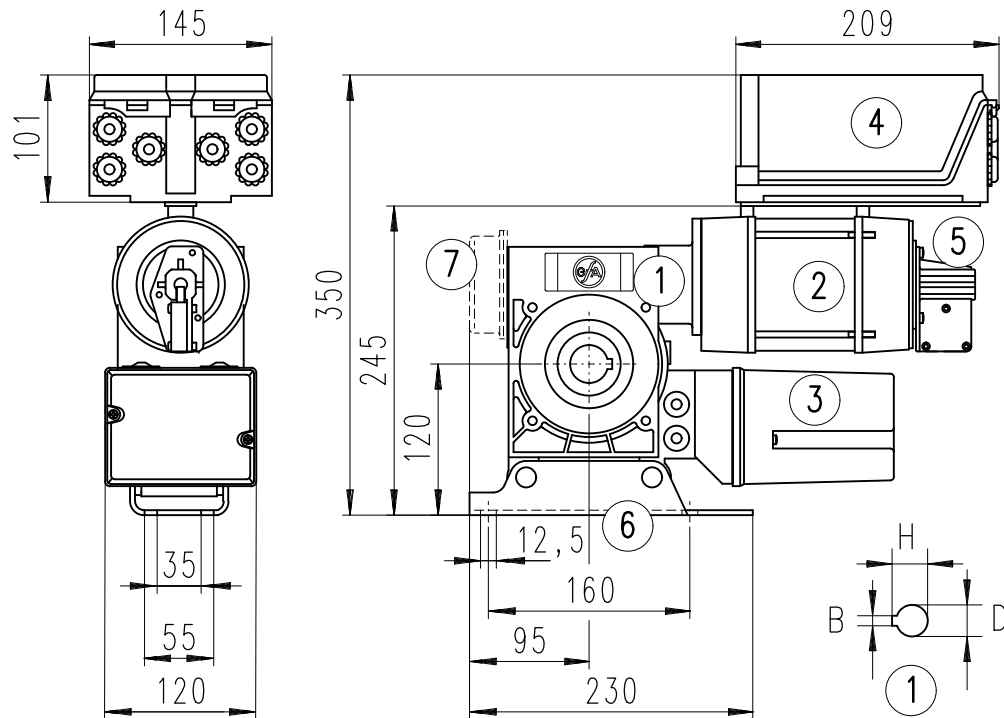

## Model NHK Manual crank

- ① Hollow shaft / worm gear within safety brake
- ② Electric motor
- ③ Limit switch
- ④ Removable reversing contactor with 0.7m cable
- ⑤ Emergency manual operation
- ⑥ floating foot for vertical and horizontal installation
- ⑦ electromagnetic spring operated brake with manual release (only at SI 17.24)

Hollow shaft diameter D [mm]	B [mm]	H [mm]
25,40	6,35	28,0
30,00	8,0	33,3
31,75	6,35	34,7

### Max. handforce (N)

Model	NHK	KNH
SI 17.15	75	100
SI 17.24	90	120

- Subject to dimensional and structural changes  
 - deviations in the overall length and the motor diameter are possible in special sizes

# TECHNICAL DATA

SI 25.10 / SI 25.15 / SI 25.15 WS / S I 40.10 / SI 40.15 / SI 55.10 / SI 55.15

52230007

Size		SI 25.10	SI 40.10	SI 55.10
output torque	Nm	250	400	550
Locking torque	Nm	635	1020	1400
output revolutions	min <sup>-1</sup>	10	10	10
motor performance	kW	0,55	0,75	0,75
operational voltage	V	3 x 230/400	3 x 230/400	3 x 230/400
frequency	Hz	50	50	50
control voltage	V	24	24	24
nominal motor current	A	3,5 / 2,0	4,8 / 2,8	8,0 / 4,6
motor duty cycle	ED	S3-60%	S3-60%	S3-60%
power supply / fusing on attachment side		5x1,5 <sup>2</sup> / 10A delay	5x1,5 <sup>2</sup> / 10A delay	5x1,5 <sup>2</sup> / 10A delay
limit switch range, max. revolutions of the hollow shaft. E 20 Standard at DES		10 (20, 60, 110)	10 (20, 60, 110)	10 (20, 60, 110)
permissible temperature range (in the case of deviation, please check)		-5°C / +40°C	-5°C / +40°C	-5°C / +40°C
permanent sound emission	dB(A)	< 70	< 70	< 70
class of protection	IP	54	54	54
ELEKTROMATEN® weight	kg	23	26	30

Size		SI 25.15	SI 25.15 WS Single phase	SI 40.15	SI 55.15
output torque	Nm	250	250	400	550
Locking torque	Nm	635	635	1020	1400
output revolutions	min <sup>-1</sup>	15	15	15	15
motor performance	kW	0,40	0,75	1,10	1,10
operational voltage	V	3 x 230/400	1 x 230	3 x 230/400	3 x 230/400
frequency	Hz	50	50	50	50
control voltage	V	24	24	24	24
nominal motor current	A	3,1 / 1,8	8,0	4,6 / 2,7	7,3 / 4,2
motor duty cycle	ED	S3-60%	S3-40%	S3-60%	S3-60%
power supply / fusing on attachment side		5x1,5 <sup>2</sup> / 10A delay	3x1,5 <sup>2</sup> / 10A delay	5x1,5 <sup>2</sup> / 10A delay	5x1,5 <sup>2</sup> / 10A delay
limit switch range, max. revolutions of the hollow shaft. E 20 Standard at DES		10 (20, 60, 110)	10 (20, 60, 110)	10 (20, 60, 110)	10 (20, 60, 110)
permissible temperature range (in the case of deviation, please check)		-5°C / +40°C	-5°C / +40°C	-5°C / +40°C	-5°C / +40°C
permanent sound emission	dB(A)	< 70	< 70	< 70	< 70
class of protection	IP	54	54	54	54
ELEKTROMATEN® weight	kg	21	27	28	30

In the case of structurally similar ELEKTROMATEN® or special sizes, deviations are possible, in particular in the output torque, output revolutions and the motor data. In each case, the details on the nameplate apply.

# DIMENSIONS

SI 25.10 / SI 25.15 / SI 25.15 WS / SI 40.10 / SI 40.15 / SI 55.10 / SI 55.15

52240034

Capacitor (only on single phase model)

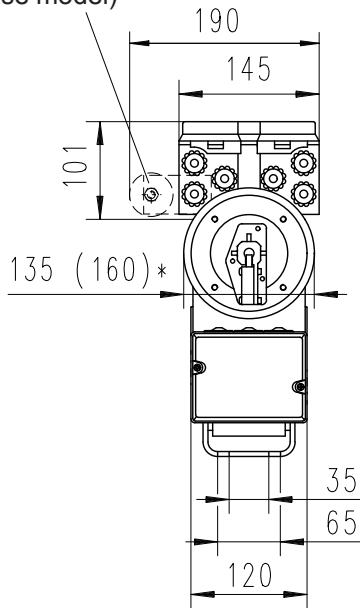

**Model NHK**  
Manual crank

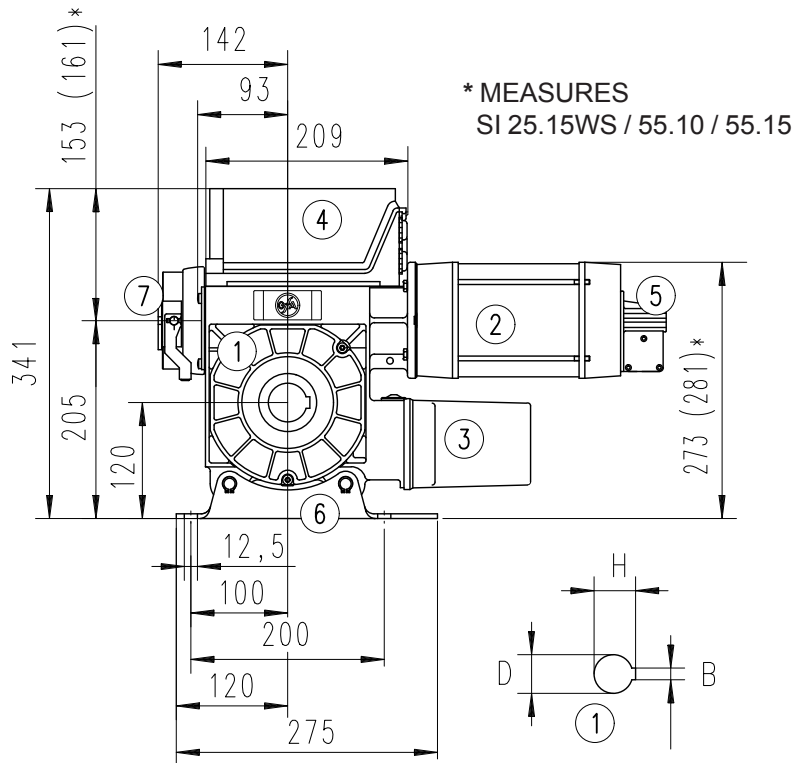

\* MEASURES  
SI 25.15WS / 55.10 / 55.15

- ① Hollow shaft / worm gear within safety brake
- ② Electric motor
- ③ Limit switch
- ④ Removable reversing contactor with 0.7m cable
- ⑤ Emergency manual operation
- ⑥ floating foot for vertical and horizontal installation
- ⑦ electromagnetic spring operated brake with manual release (only at SI 55.10 / SI 55.15)

Model	Hollow shaft diameter D [mm]	B [mm]	H [mm]
SI 25.10	30	8	33,3
SI 25.15	30	8	33,3
SI 25.15 WS	30	8	33,3
SI 40.10	40	12	43,3
SI 40.15	40	12	43,3
SI 55.10	40	12	43,3
SI 55.15	40	12	43,3

## Max. handforce ( N )

Model	NHK	KNH
SI 25.10	85	110 ( i=2 )
SI 25.15	85	110 ( i=2 )
SI 25.15 WS	85	110 ( i=2 )
SI 40.10	130	85 ( i=3,5 )
SI 40.15	130	85 ( i=3,5 )
SI 55.10	285	165 ( i=3,5 )
SI 55.15	285	165 ( i=3,5 )

- Subject to dimensional and structural changes
- deviations in the overall length and the motor diameter are possible in special sizes

# TECHNICAL DATA SI 25.24 / SI 25.35 / SI 35.30 / SI 40.24

52230020

Size		SI 25.24	SI 25.35
output torque	Nm	250	250
Locking torque	Nm	635	635
output revolutions	min <sup>-1</sup>	24	35
motor performance	kW	0,85	0,85
operational voltage	V	3 x 230 / 400	3 x 230 / 400
frequency	Hz	50	50
control voltage	V	24	24
nominal motor current	A	3,7 / 2,1	3,7 / 2,1
motor duty cycle	ED	S3-60%	S3-60%
power supply / fusing on attachment side		5 x 1,5 <sup>2</sup> / 10 A delay	5 x 1,5 <sup>2</sup> / 10 A delay
limit switch range, max. revolutions of the hollow shaft		10 (60, 110)	10 (60, 110)
permissible temperature range (in the case of deviation, please check)		-5°C / +40°C	-5°C / +40°C
permanent sound emission	dB(A)	< 70	< 70
class of protection	IP	54	54
ELEKTROMATEN® weight	kg	26	26

Size		SI 35.30	SI 40.24
output torque	Nm	350	400
Locking torque	Nm	890	1020
output revolutions	min <sup>-1</sup>	30	24
motor performance	kW	1,10	1,10
operational voltage	V	3 x 230 / 400	3 x 230 / 400
frequency	Hz	50	50
control voltage	V	24	24
nominal motor current	A	4,6 / 2,7	4,6 / 2,7
motor duty cycle	ED	S3-60%	S3-60%
power supply / fusing on attachment side		5 x 1,5 <sup>2</sup> / 10 A delay	5 x 1,5 <sup>2</sup> / 10 A delay
limit switch range, max. revolutions of the hollow shaft		10 (60, 110)	10 (60, 110)
permissible temperature range (in the case of deviation, please check)		-5°C / +40°C	-5°C / +40°C
permanent sound emission	dB(A)	< 70	< 70
class of protection	IP	54	54
ELEKTROMATEN® weight	kg	29	29

In the case of structurally similar ELEKTROMATEN® or special sizes, deviations are possible, in particular in the output torque, output revolutions and the motor data. In each case, the details on the nameplate apply.

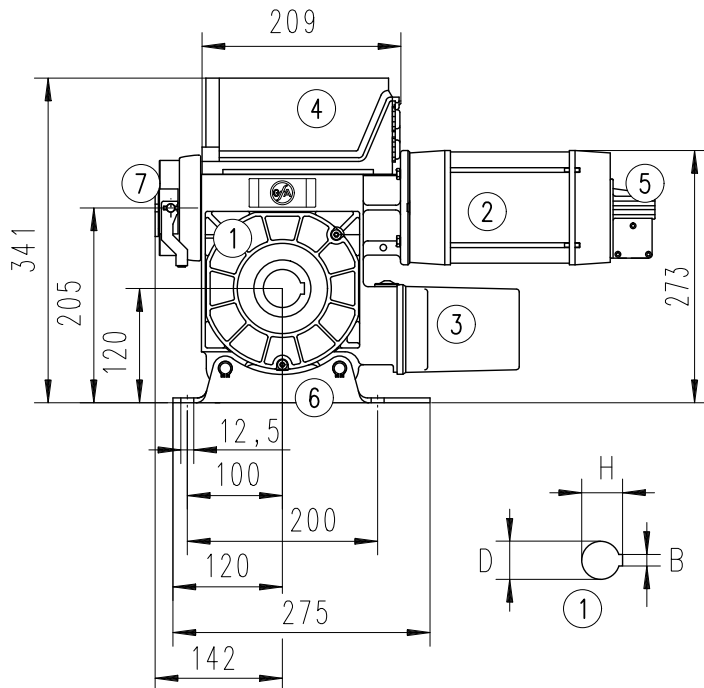
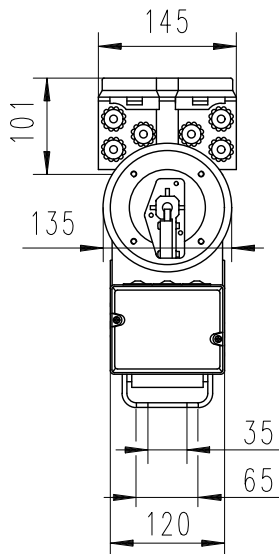

**Model NHK**  
Manual crank

- ① Hollow shaft / worm gear within safety brake
- ② Electric motor
- ③ Limit switch
- ④ Removable reversing contactor with 0.7m cable
- ⑤ Emergency manual operation
- ⑥ floating foot for vertical and horizontal installation
- ⑦ electromagnetic spring operated brake with manual release

**Max. handforce ( N )**

Model	Hollow shaft diameter D [mm]	B [mm]	H [mm]
SI 25.24-30	30	8	33,3
SI 25.35-30	30	8	33,3
SI 35.30-40	40	12	43,3
SI 40.24-40	40	12	43,3

Model	NHK	KNH
SI 25.24	170	100 ( i=3,5 )
SI 25.35	180	105 ( i=3,5 )
SI 35.30	210	125 ( i=3,5 )
SI 40.24	225	130 ( i=3,5 )

- Subject to dimensional and structural changes  
 - deviations in the overall length and the motor diameter are possible in special sizes

# TECHNICAL DATA

SI 75.10 / SI 75.15 / SI 100.10 / SI 100.24 / SI 140.7 / SI 60.24 / SI 75.24

52230021

Size		SI 75.10	SI 75.15	SI 100.10	SI 100.24
output torque	Nm	750	750	1000	1000
Locking torque	Nm	2840	2840	2840	2840
output revolutions	min <sup>-1</sup>	10	15	10	24
motor performance	kW	1,10	1,10	1,30	3,0
operational voltage	V	3 x 230/400	3 x 230/400	3 x 230/400	3 x 230/400
frequency	Hz	50	50	50	50
control voltage	V	24	24	24	24
nominal motor current	A	7,8 / 4,5	7,1 / 4,1	11,3 / 6,5	12,0 / 6,9
motor duty cycle	ED	S3-60%	S3-60%	S3-60%	S3-60%
power supply / fusing on attachment side		5 x 2,5 <sup>2</sup> / 16 A delay	5 x 2,5 <sup>2</sup> / 16 A delay	5 x 2,5 <sup>2</sup> / 16 A delay	5 x 2,5 <sup>2</sup> / 16 A delay
limit switch range, max. revolutions of the hollow shaft		10 (60, 110)	10 (60, 110)	10 (60, 110)	10 (60, 110)
permissible temperature range (in the case of deviation, please check)		-5°C / +40°C	-5°C / +40°C	-5°C / +40°C	-5°C / +40°C
permanent sound emission	dB(A)	< 70	< 70	< 70	< 70
class of protection	IP	54	54	54	54
ELEKTROMATEN® weight	kg	47	47	49	55

Size		SI 140.7	SI 60.24	SI 75.24
output torque	Nm	1400	600	750
Locking torque	Nm	2840	2840	2840
output revolutions	min <sup>-1</sup>	7	24	24
motor performance	kW	1,10	1,50	2,00
operational voltage	V	3 x 230/400	3 x 230/400	3 x 230/400
frequency	Hz	50	50	50
control voltage	V	24	24	24
nominal motor current	A	7,1 / 4,1	6,8 / 3,9	8,1 / 4,7
motor duty cycle	ED	S3-60%	S3-60%	S3-60%
power supply / fusing on attachment side		5 x 2,5 <sup>2</sup> / 16 A delay	5 x 2,5 <sup>2</sup> / 16 A delay	5 x 2,5 <sup>2</sup> / 16 A delay
limit switch range, max. revolutions of the hollow shaft		10 (60, 110)	10 (60, 110)	10 (60, 110)
permissible temperature range (in the case of deviation, please check)		-5°C / +40°C	-5°C / +40°C	-5°C / +40°C
permanent sound emission	dB(A)	< 70	< 70	< 70
class of protection	IP	54	54	54
ELEKTROMATEN® weight	kg	55	44	48

In the case of structurally similar ELEKTROMATEN® or special sizes, deviations are possible, in particular in the output torque, output revolutions and the motor data. In each case, the details on the nameplate apply.

# DIMENSIONS

SI 75.10 / SI 75.15 / SI 100.10 / SI 100.24 / SI 140.7 / SI 60.24 / SI 75.24

52240036

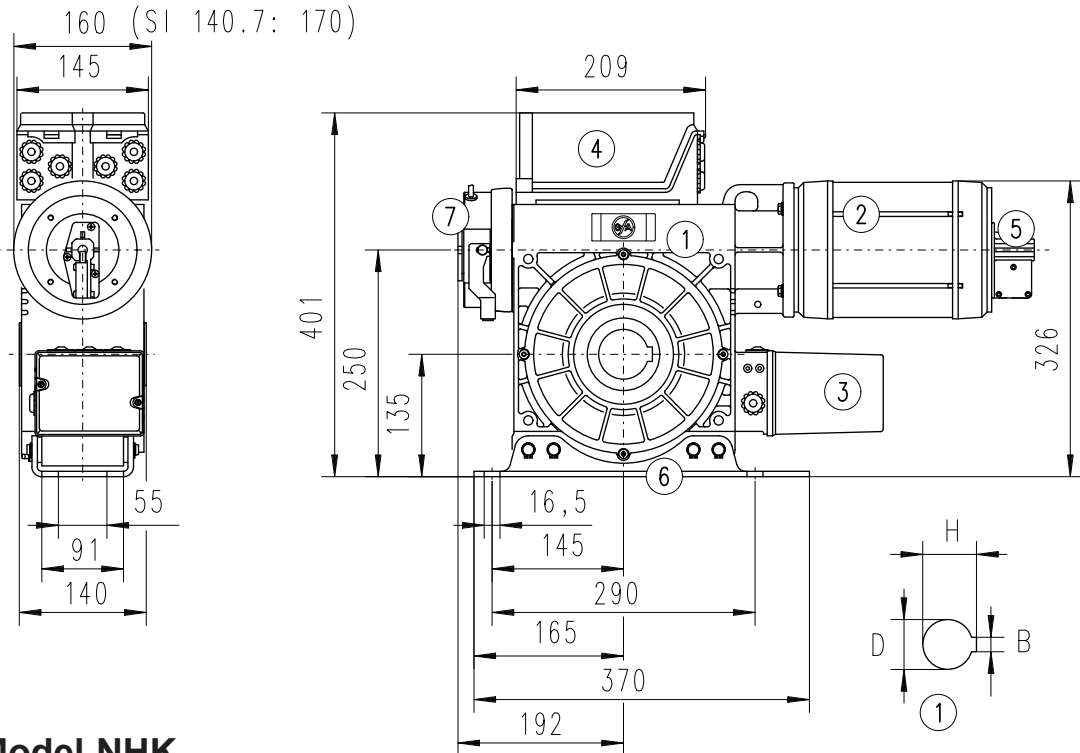

**Model NHK**  
Manual crank

- ① Hollow shaft / worm gear within safety brake
- ② Electric motor
- ③ Limit switch
- ④ Removable reversing contactor with 0.7m cable
- ⑤ Emergency manual operation
- ⑥ floating foot for vertical and horizontal installation
- ⑦ electromagnetic spring operated brake with manual release

## Max. handforce ( N )

Model	Hollow shaft diameter D [mm]	B [mm]	H [mm]
SI 75.10	55	16	59,3
SI 75.15	55	16	59,3
SI 100.10	55	16	59,3
SI 100.24	55	16	59,3
SI 140.7	55	16	59,3
SI 60.24	55	16	59,3
SI 75.24	55	16	59,3

Model	NHK	KNH
SI 75.10	285	230 ( i=3,5 )
SI 75.15	285	230 ( i=3,5 )
SI 100.10	345	280 ( i=3,5 )
SI 100.24	200	160 ( i=3,5 )
SI 140.7	250	200 ( i=3,5 )
SI 60.24	190	155 ( i=3,5 )
SI 75.24	285	230 ( i=3,5 )

- Subject to dimensional and structural changes
- deviations in the overall length and the motor diameter are possible in special sizes

## Top-mounted drive (SI 14.15 / SI 14.20, Fig. 1/2)

Inspect drive shaft for damage or dirt, e. g. dents, weld splashes, paint, tape ect. Generously grease hollow shaft and stub shaft. Align keyway and carefully slide unit onto stub shaft key appears.

In a continuous shaft groove, the key (1) is secured against displacement with 2 screws on both sides of the gear hollow shaft.

In order to mount the torque support and/or flange bracket (2), holes should be provided in the bracket on the attachment side. The tightening torque required for the fixings is 20 Nm.

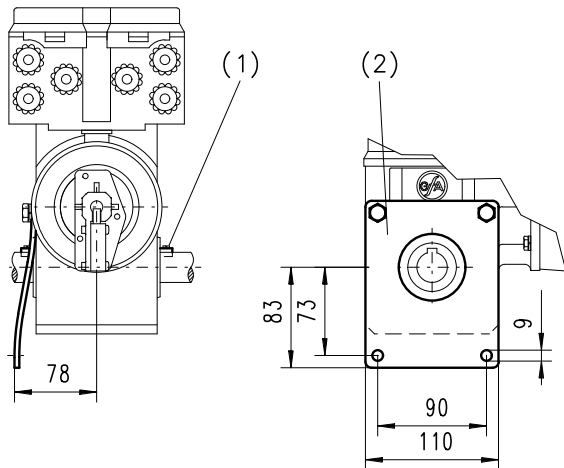

Fig. 1: Top-mounted drive with torque support

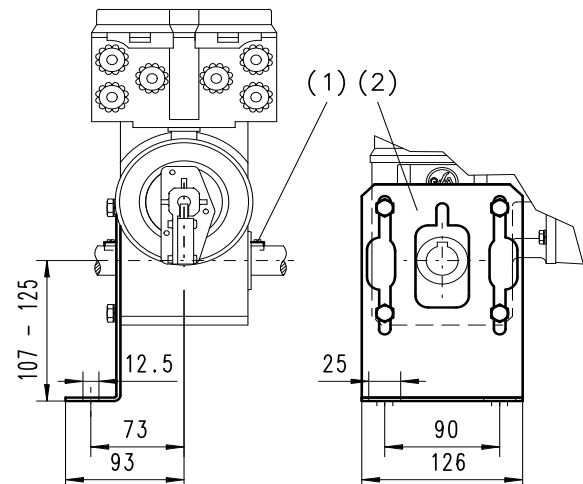

Fig. 2: Top-mounted drive with flange bracket

## Top-mounted drive (Fig. 3)

Inspect drive shaft for damage or dirt, e. g. dents, weld splashes, paint, tape ect. Generously grease hollow shaft and stub shaft. Align keyway and carefully slide unit onto stub shaft key appears.

Do not fix ELEKTROMATEN axially wehn mounting. For axial fixing use the stub shaft on the bearing side.

Standard floating foot for vertical and horizontal installation.

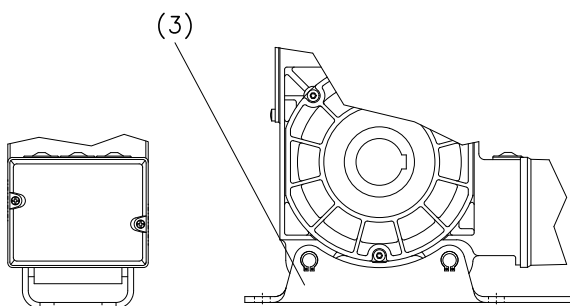

Fig. 3: safe drive with floating foot

If the gearbox housing is provided with an additional coat of paint, the shaft sealing rings should not be painted under any circumstances.

The emergency manual operation is provided in order to open or close the door without an electrical supply.



## Warning! Danger of injury through improper operation!

- Before using the emergency manual operation, the main switch should be switched off.
- The emergency manual operation should only be carried out when the motor is stationary.
- A secure position should be adopted to operate the equipment manually.
- In the case of ELEKTROMATEN® with a spring-operated brake, the door should be opened or closed with the brakes on.
- For safety reasons, the brakes should only be lifted for inspection.
- Precautions must be taken on the construction site to prevent the brake from being lifted unintentionally.



The door should not be moved beyond the normal end positions by the emergency manual operation, since this will operate the safety limit switch. Electrical operation of the door is then no longer possible.

## Emergency manual operation by the manual hand crank (NHK) (Fig. 1)

- The manual crank must be inserted into the manual switch receptacle and is turned whilst pressing gently until it engages, on that way the control circuit would be interrupted. It is no longer possible to operate the door electrically.
- The door can be opened and closed by turning the manual crank
- After pulling out the manual crank, electrical operation is once possible.

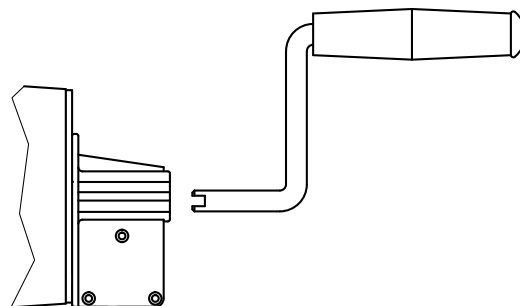

Fig. 1: Emergency manual operation by the manual hand crank

Execution: **SK** "Rapid hand chain operator" (Fig. 1)  
Execution: **KNH** "Chain operator" (without Fig.)

## Emergency manual operation

### "Rapid hand chain operator" (Fig. 1)

- The red handle of the engaging and disengaging mechanism is first pulled lightly until it stops (max. operating force 50N), the control circuit is now interrupted, it is no longer possible to operate the door electrically.
- The door can be opened and closed by pulling the chain (2).
- By lightly pulling the engaging and disengaging mechanism by the green handle until it stops (3) (max. operating force 50N), the control circuit is re-made and the door is electrically operational.

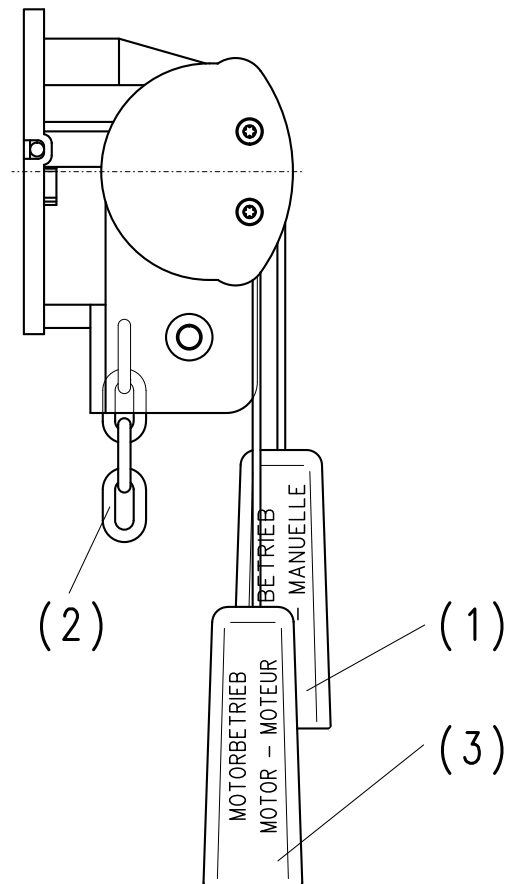

Fig. 1: Emergency manual operation  
"Rapid hand chain operator"

### Variation of the hand chain length (Fig. 2)

- The hand chain can be opened at the connection point and can be lengthened or shortened with connecting links.
- The connecting links should be bent together carefully.
- When changing the chain length, care should be taken that the chain is cross - assembled (Fig. 2).

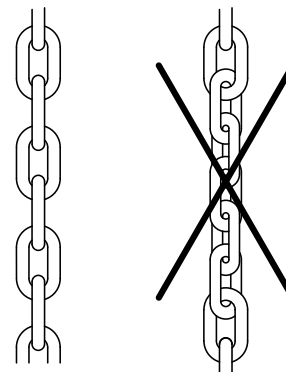

Fig. 2: Variation of the hand  
chain length

# VOLTAGE CHANGEOVER OF MOTORS

52390009



## Warning! Danger to life through electric shock

Before starting assembly, disconnect the cables from the electricity supply and check that they are dead.

The motor windings are wired so that it is possible to operate the ELEKTROMATEN® on a 3 X 400 V or 3 X 230 V supply.

Ex factory the motor is wired in star connection for a 3 X 400 V mains. The motor should be in delta connection for a 230 V mains.

In order to change-over the voltage of the motor, the ends of the coils should be re-arranged, as shown in Fig. 1.

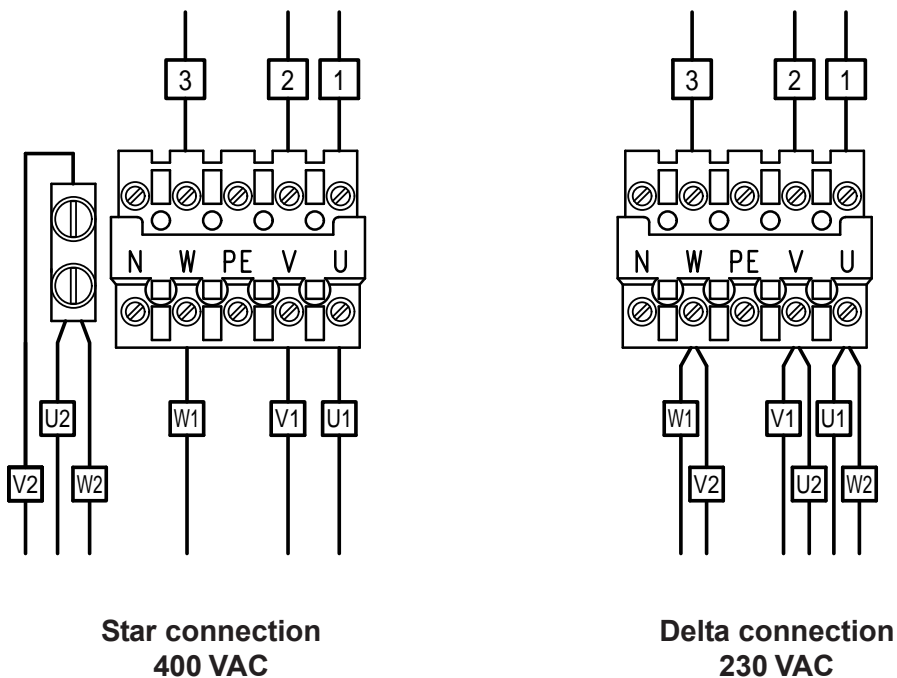

Fig. 1: Motor terminals plug in connection



When attaching the motor cables, care should be taken that the individual cables are inserted deep enough to ensure secure connection. This connection can be checked by pulling the cables.

If the motor is changed over for operation in a 3 X 230 V mains, the reversing contactor board should also be modified.

At Universal - contactor board, fit link G between T1 -T2.  
(electrical operating 51171134)

Adjusting the working limit switches sets the upper and lower stopping positions of the door. In order to make this adjustment, the ELEKTROMATEN should be connected electrically. The limit switch board (Fig. 2: limit switch board with 7 limit switches) is accessible after unscrewing the limit switch cover. If no external control devices are fitted, the door can be moved in dead man operation using the built-in OPEN, CLOSE and STOP push buttons (S11-13) where a reversing starter has also been supplied.

The door should open when the pushbutton S11 is operated, otherwise the two phases L1 and L2 should be exchanged at the contactor with the current switched off.

## Lower stopping position

In order to adjust the limit switch for the lower stopping position of the door, the following steps should be carried out (Fig. 1):

- shut the door
- rotate switching cam (1) of the limit switch "CLOSE" to the middle of the switching cam (2) and tighten the coarse adjustment screw (3) with the hexagonal socket screw key supplied
- open door until the limit switch "CLOSE" switches back again
- close door again
- correct lower stopping position, possibly by turning the fine adjustment screw (4); the fine adjustment screw can be moved from both sides with the hexagonal socket screw key supplied
- the "CLOSED SAFETY" limit is pre-adjusted automatically by the limit switch adjustment "CLOSE"
- the switch point for the safety limit switch must be corrected, possibly using the fine adjustment screw, so that the door still stops safely if the direction of rotation is reversed or the operating limit switch fails.

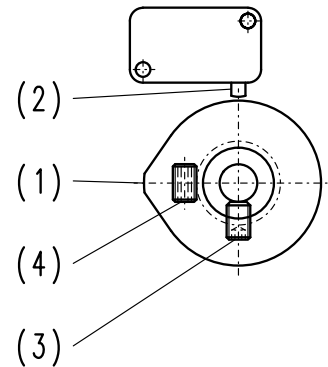

Fig. 1: Limit switch cam

## Upper stopping position

After opening the door, the "OPEN" and/or "OPEN SAFETY" limit switch are adjusted similarly to the lower position.

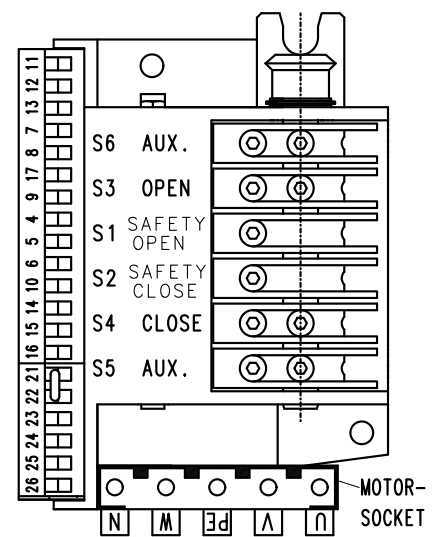

Fig. 2: Limit switch board

## SAFETY CIRCUIT

The terminals 21 to 26 on the limit switch board (Fig. 2) are reserved for the safety circuit. An interruption of the safety circuit causes the control current to be interrupted. Electrical operation is then no longer possible.

The terminals 23 to 26 on the limit switch board are connected to the safety switch of the emergency manual operation and/or the thermal protection of the motor.

The terminals 21, 22 on the limit switch board are provided with jumpers. Additional safety switches can be attached instead of these jumpers.

Adjusting the working limit switches sets the upper and lower stopping positions of the door. In order to make this adjustment, the ELEKTROMATEN should be connected electrically. The limit switch board (Fig. 2: limit switch board with 7 limit switches) is accessible after unscrewing the limit switch cover. If no external control devices are fitted, the door can be moved in dead man operation using the built-in OPEN, CLOSE and STOP push buttons (S11-13) where a reversing starter has also been supplied.

The door should open when the pushbutton S11 is operated, otherwise the two phases L1 and L2 should be exchanged at the contactor with the current switched off.

## Lower stopping position

In order to adjust the limit switch for the lower stopping position of the door, the following steps should be carried out (Fig. 1):

- shut the door
- rotate switching cam (1) of the limit switch "CLOSE" to the middle of the switching cam (2) and tighten the coarse adjustment screw (3) with the hexagonal socket screw key supplied
- open door until the limit switch "CLOSE" switches back again
- close door again
- correct lower stopping position, possibly by turning the fine adjustment screw (4); the fine adjustment screw can be moved from both sides with the hexagonal socket screw key supplied
- the "CLOSED SAFETY" limit is pre-adjusted automatically by the limit switch adjustment "CLOSE"
- the switch point for the safety limit switch must be corrected, possibly using the fine adjustment screw, so that the door still stops safely if the direction of rotation is reversed or the operating limit switch fails.

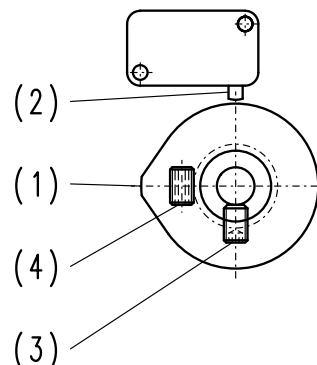

Fig. 1: Limit switch cam

## Upper stopping position

After opening the door, the "OPEN" and/or "OPEN SAFETY" limit switch are adjusted similarly to the lower position.

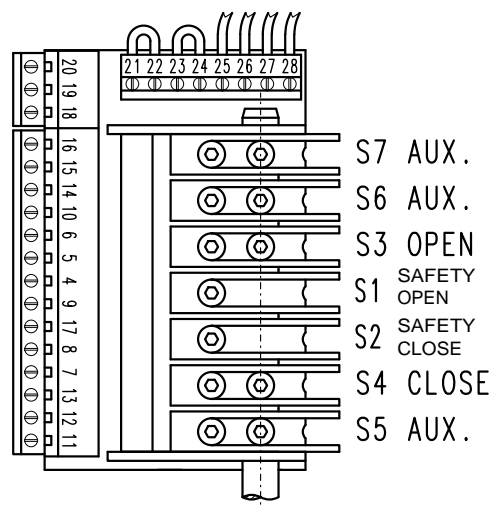

Fig. 2: Limit switch board

## SAFETY CIRCUIT

The terminals 21 to 28 on the limit switch board (Fig. 2) are reserved for the safety circuit. An interruption of the safety circuit causes the control current to be interrupted. Electrical operation is then no longer possible.

The terminals 25 to 28 on the limit switch board are connected to the safety switch of the emergency manual operation and/or the thermal protection of the motor.

The terminals 21 to 24 on the limit switch board are provided with jumpers. Additional safety switches can be attached instead of these jumpers.

# DIGITAL LIMIT SWITCH (type DES)

52340012

The digital limit (type DES) is an absolute position encoder for doors.

Evaluation and installation of the limit positions is done through the control panel, which corresponds to the electronic limit.

For installation only a 6 pole plug has to be connected. Adjustment of mechanical parts is not required.

The connections for the safety circuit (e.g. safety limits) are on the side of the DES.

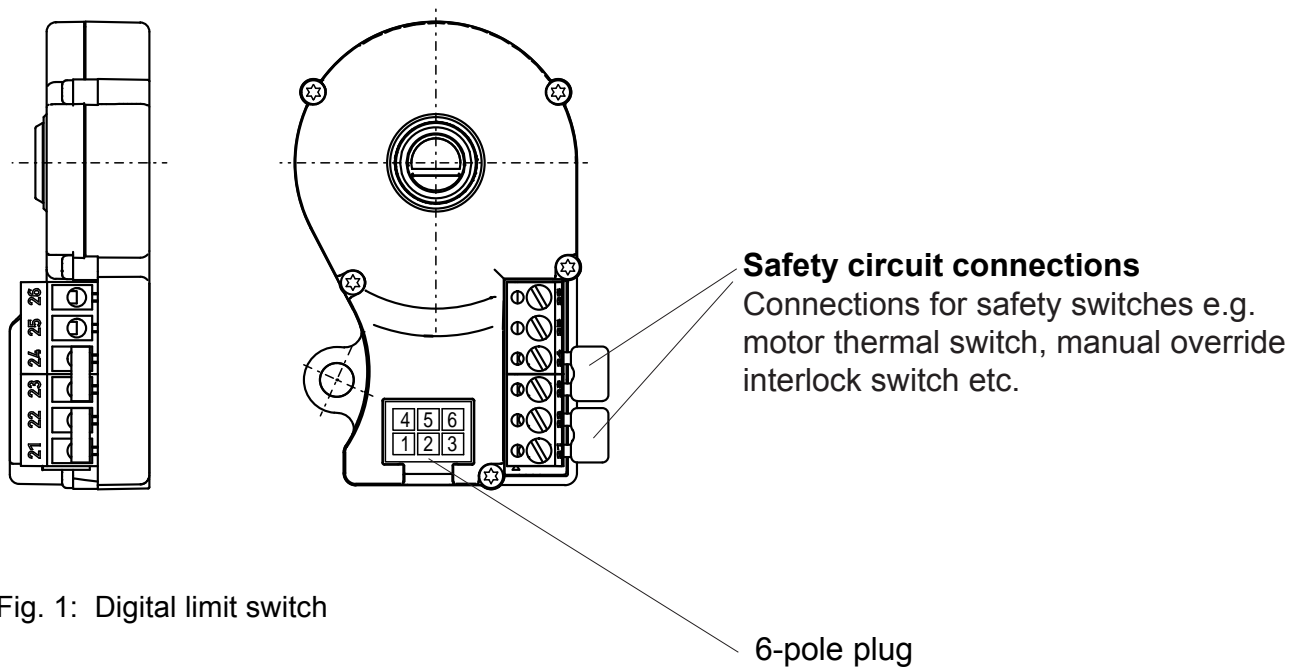

Fig. 1: Digital limit switch



The maintenance of power-assisted windows, doors and gates should only be carried out by persons authorised by the employer and who are familiar with the respective maintenance work.

## Directions for the inspector

### Gearbox:

The gear construction is maintenance-free and has lifetime lubrication. The output shaft should be kept rust-free.

### Attachments:

All attachment screws should be inspected to make sure they are fitted securely and are in perfect condition.

### Brake (if fitted)

The correct function of the brake should be checked during the annual inspection.

Where there is increased wear, the brake lining or - once the rectifier has been disconnected - the entire brake can be exchanged.

### Safety brake (if fitted):

In a properly functioning drive, the safety brake is in order and does not need to be inspected. Constructional measures ensure that the safety brake revolves without any load. If the worm gear fails, the safety brake holds the door without jerk in every position. Even if the safety brake fails, the gear construction locks and the leaf is held.

The ELEKTROMATEN® is assembled completely and is wired ready for connection. Transport and any storage should be carried out in the provided (or equivalent) packaging to avoid damage.

On disposal the ELEKTROMATEN®,

- metals
- plastic parts
- electric parts
- lubricants

must be separated.

## SERVICE / REPLACEMENT PARTS / ACCESSORIES

Please note that replacement parts and accessories which have not been supplied by us have also not been tested and released by us.

Fitting and / or using such products can therefore negatively affect the above properties of the ELEKTROMATEN® and thus reduce its safety.

GfA accepts no liability for nor provides any guarantee against damage caused by using non-original replacement parts and accessories.

Faults which the users cannot rectify themselves should only be corrected by the manufacturer of the door equipment or another specialist firm. Replacement parts can also be requested from such firms.

